

Copyright © 2008, Wimborne Publishing Ltd
(Sequoia House, 398a Ringwood Road, Ferndown, Dorset BH22 9AU, UK)
and TechBites Interactive Inc.,
(PO Box 857, Madison, Alabama 35758, USA)

All rights reserved.

The materials and works contained within EPE Online — which are made available by Wimborne Publishing Ltd and TechBites Interactive Inc — are copyrighted.

TechBites Interactive Inc and Wimborne Publishing Ltd have used their best efforts in preparing these materials and works. However, TechBites Interactive Inc and Wimborne Publishing Ltd make no warranties of any kind, expressed or implied, with regard to the documentation or data contained herein, and specifically disclaim, without limitation, any implied warranties of merchantability and fitness for a particular purpose.

Because of possible variances in the quality and condition of materials and workmanship used by readers, EPE Online, its publishers and agents disclaim any responsibility for the safe and proper functioning of reader-constructed projects based on or from information published in these materials and works.

In no event shall TechBites Interactive Inc or Wimborne Publishing Ltd be responsible or liable for any loss of profit or any other commercial damages, including but not limited to special, incidental, consequential, or any other damages in connection with or arising out of furnishing, performance, or use of these materials and works.

READERS' TECHNICAL ENQUIRIES

We are unable to offer any advice on the use, purchase, repair or modification of commercial equipment or the incorporation or modification of designs published in the magazine. We regret that we cannot provide data or answer queries on articles or projects that are more than five years' old. We are not able to answer technical queries on the phone.

PROJECTS AND CIRCUITS

All reasonable precautions are taken to ensure that the advice and data given to readers is reliable. We cannot, however, guarantee it and we cannot accept legal responsibility for it. A number of projects and circuits published in EPE employ voltages that can be lethal. You should not build, test, modify or renovate any item of mains-powered equipment unless you fully understand the safety aspects involved and you use an RCD adaptor.

COMPONENT SUPPLIES

We do not supply electronic components or kits for building the projects featured; these can be supplied by advertisers in our publication Practical Everyday Electronics. Our web site is located at www.epemag.com

We advise readers to check that all parts are still available before commencing any project.



To order your copy for only \$18.95 for 12 issues go to www.epemag.com

PIC PULSOMETER

RICHARD HINCKLEY

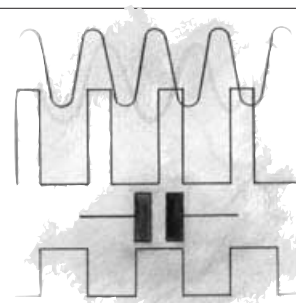

Accurately measures and displays pulse timings, frequency and capacitance.

THIS project was started because the author had a need to measure sub-microsecond pulses and frequencies in the megahertz range. Along the way it was found that capacitance could be measured at little extra cost – an important feature as the author is the proud owner of several hundred capacitors whose values he has difficulty reading!

FUNDAMENTALS

If a pulse is used to gate an oscillator or clock of known frequency, its duration can be measured by counting the clock pulses. To achieve a high resolution the clock must have a short period, or high frequency, and in this design the clock has a frequency of 40MHz, giving a period of 25ns.

This method can also be used to calculate the frequency of the incoming pulses indirectly from the formula:

$$\text{Frequency} = 1/\text{Period}$$

The accuracy of this method is limited at higher frequencies. For example, with a 40MHz clock, a 21MHz input signal would

be measured as 40MHz, since only one clock pulse would be counted.

The other method of measuring frequency is to use a pulse of known duration (e.g. one second) to gate the input signal. This direct method has high accuracy at higher frequencies, but poor accuracy at lower ones – e.g. a 10.9Hz signal would be measured as 10Hz. In this design both methods are used.

The absolute accuracy of the Pulsometer is determined by the accuracy of the timing crystals used, as there is no correction mechanism. This gives an accuracy of 100ppm.

The Pulsometer is designed to measure pulses from 74HC/HCT and 4000 series CMOS logic, with a High (logic 1) of 3.25V minimum and a Low (logic 0) of 1V maximum. It will also measure a.c. signals of sufficient amplitude, and TTL signals up to around 10MHz.

For small a.c. signals, a preamplifier will be needed, perhaps based on Raymond Haigh's excellent design (*Practical*

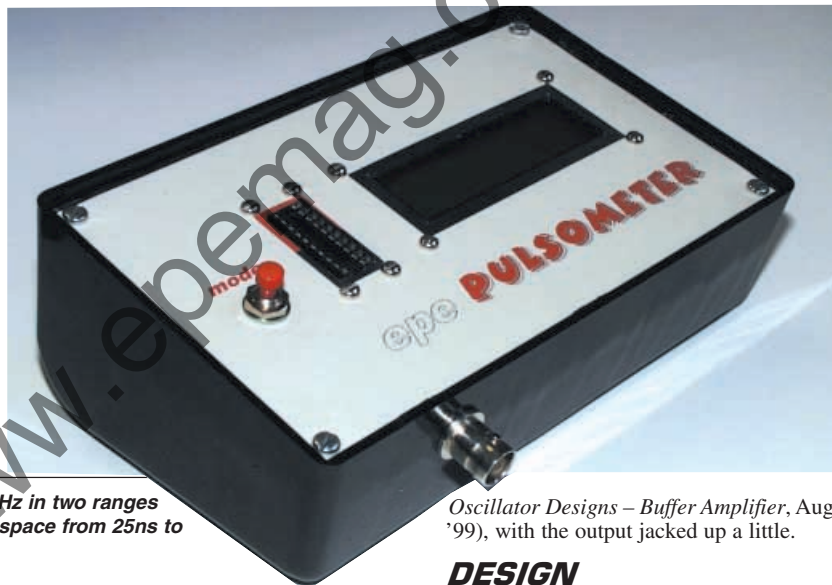

SPECIFICATION . . .

| | |
|----------------------|--|
| Frequency: | 0.00015Hz to 40MHz in two ranges |
| Duration: | Period, mark and space from 25ns to 1.9 hours |
| Capacitance: | 1pF to 999µF |
| Resolution: | 25ns |
| Precision: | 6 most significant digits |
| Display: | 16-character 1-line backlit l.c.d. |
| Technology: | PIC16F84 control and 74HC series logic |
| Power Supply: | 9V to 12V external supply |

Oscillator Designs – Buffer Amplifier, Aug '99), with the output jacked up a little.

DESIGN

In theory the design of a circuit such as the Pulsometer should be easy. All that has to be done is to feed the gated signal into a PIC, count the pulses, do some simple arithmetic, and display the result.

Unfortunately, a PIC16F84 is not fast enough to count pulses above 250kHz (at an optimistic best), so the input signal has to be scaled down first, but without losing precision.

The design is shown in the simplified block diagram in Fig.1. The mode of operation is decided by the user (push-switch selected) and this causes the PIC to control the rest of the circuit accordingly. This works cyclically in that the input signal is sampled, the result calculated and then displayed, after which the cycle starts again.

The signal is fed in via a buffer to cater for inputs of varying amplitudes. If the

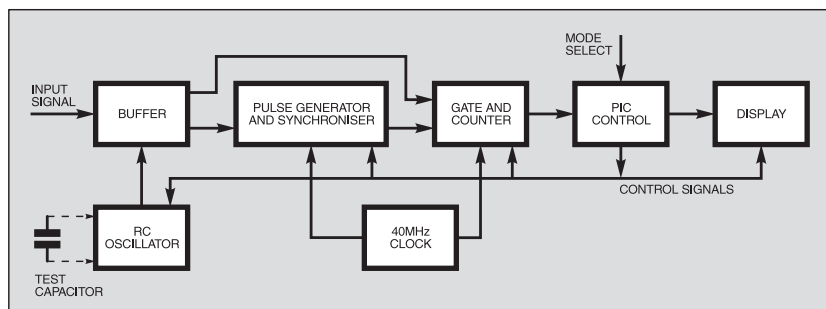

Fig.1. Simplified block diagram for the PIC Pulsometer.

time is to be measured, a pulse is generated which represents the period, mark or space of the incoming pulse. This is then synchronised with the 40MHz clock oscillator, the resulting pulse gated with the clock, and the output fed via a counter into the PIC.

At the end of the pulse, any residual count in the counter is "flushed" into the PIC, the appropriate calculations are made, and the result displayed.

For higher frequencies, the input signal is fed straight into the Gate and Counter circuit where it is gated by a one-second pulse generated by the PIC, and counted, calculated and displayed as before.

For capacitance measurement, an RC oscillator is used to generate pulses whose period depends on the capacitance under test. The technique used gives accurate results above 10pF, and creditable ones as low as 1.8pF.

BUFFER

The input circuit diagram for the PIC Pulsometer is shown in Fig.2. The input emitter follower comprising TR1 and R3 gives high input impedance and is preceded by R1, D1 and D2. These clip the input signal to 0V and +5V (within about 0.7V), allowing for input voltages up to (at least) the 15V allowed by 4000 series logic, and for a.c. signals.

Resistor R2 forces the emitter voltage Low in the absence of an input signal, which is important when capacitance is being measured.

The emitter of TR1 feeds IC1a, a Schmitt-trigger NAND gate wired as an inverter, which sharpens up the input. Except when capacitance is being measured, the PIC keeps pin 5 of IC1b Low, and therefore pin 2 of IC1c High.

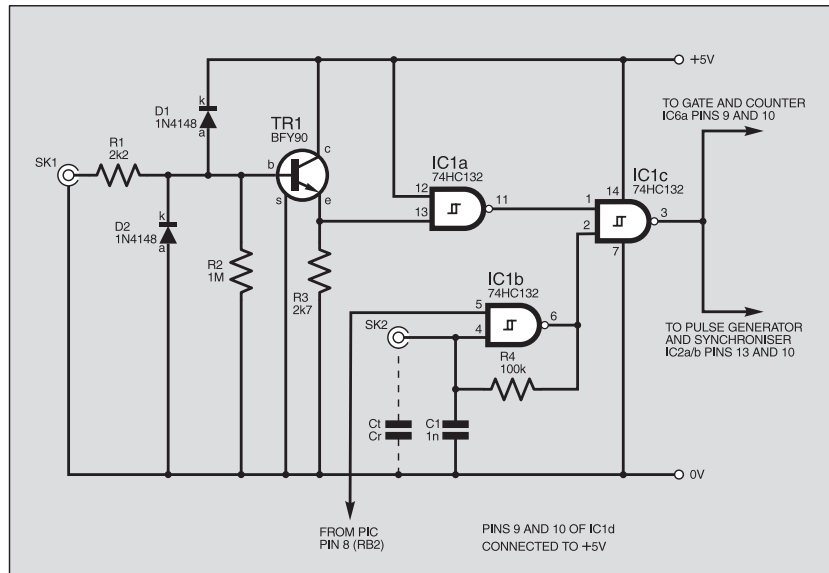

Fig.2. Circuit diagram for the buffer and RC oscillator stages.

The resulting output at pin 3 of IC1c is therefore a sharp pulse train which mirrors the input. This is then fed to the Gate and Counter circuit for high frequency measurement, and to the Pulse Generator and Synchroniser for all other measurements.

It is important to use the BFY90 transistor specified for TR1. This has a very high unity gain frequency. Other transistors – even other RF transistors such as the BF484 – give poor results in this circuit.

The purpose of the RC oscillator built around IC1b is described later. The inputs of the unused gate IC1d (pins 9 and 10) are tied to the +VE rail to prevent spurious operation.

PULSE GENERATOR AND SYNCHRONISER

The Pulse Generator and Synchroniser circuit diagram is shown in Fig.3. The circuit is required to generate a pulse which has the same time as the period of the incoming pulse train, or the same time as either the mark of a single pulse or the space between two pulses.

It relies on the fact that an Exclusive-OR (XOR) gate can be used as a controllable inverter. XOR gates are interesting devices and less-used than perhaps they should be. The usage here is described in the Logic Hints 1 panel.

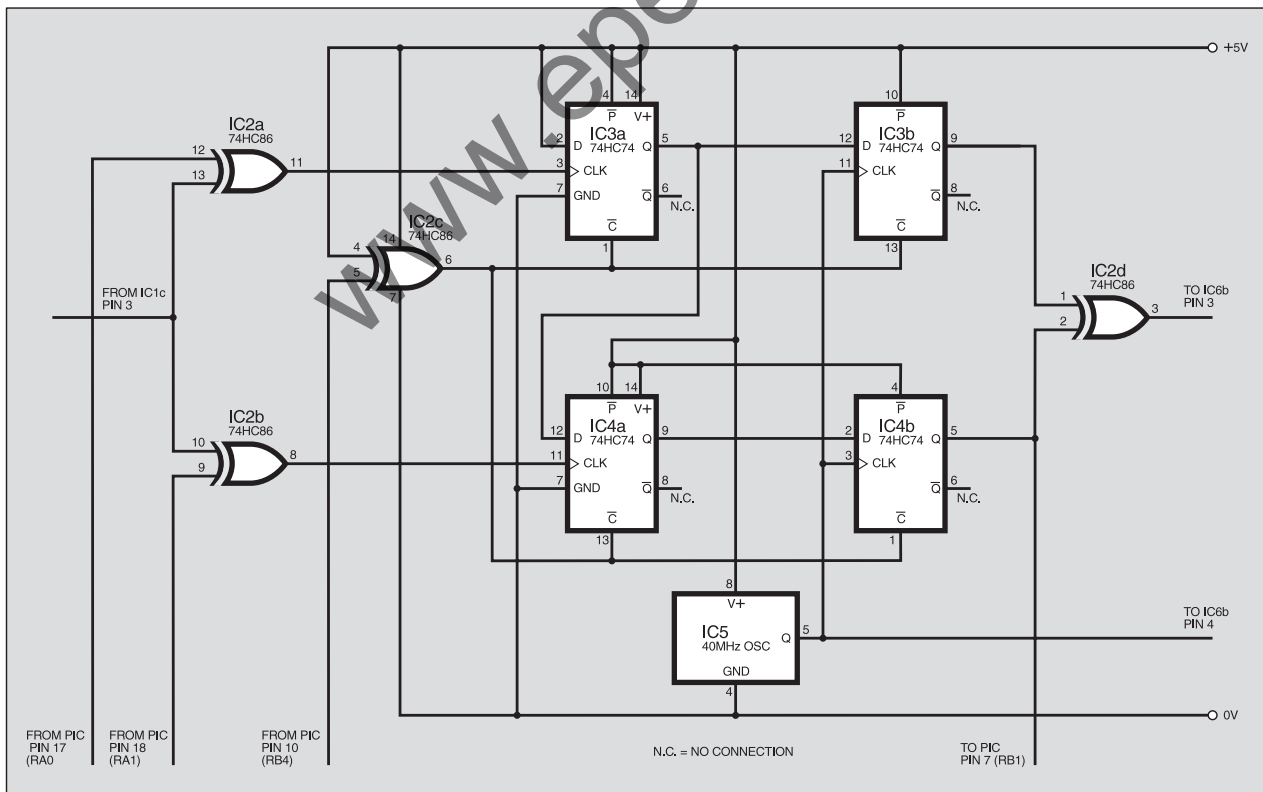

Fig.3. Circuit diagram of the PIC Pulsometer pulse generator and synchroniser stages.

Assume that the mark of a pulse is to be measured. Initially the PIC holds all the 74HC74 D-type flip-flops in a reset state by applying a High to pin 5 of IC2c. This is configured as an inverter, so a Low is present at the Clear pins. The PIC sets pin 12 of IC2a Low, so it does not invert, and pin 9 of IC2b High so that it does.

The PIC releases the reset condition by setting pin 5 of IC2c Low. The next leading edge of the input pulse passes through IC2a uninverted, and arrives at pin 3 of IC3a, the Clock input. Because the Data pin of IC3a is tied High to +5V, this causes IC3a to change state, so that its Q output changes from Low to High.

Until this point, any High at the Clock input of IC4a will have no effect, as the Data pin is connected to the Q pin of IC3a. However, the change of state of IC3a now enables IC4a. So, when the trailing edge of the input pulse arrives at IC4a's Clock input, it has been inverted by IC2b, and goes from Low to High.

This causes IC4a to change state, so its Q output goes High. Further input pulses have no effect on either IC3a or IC4a – they are locked in that state until reset by the PIC.

GLITCHES

The time difference between the Q output of IC3a going High and the Q output of IC4a going High is the same as the input pulse, and this could be used to derive a pulse to gate the 40MHz clock. However, it is not synchronised with the clock, and this can give rise to many "glitches".

This effect is reduced by feeding the Q outputs of both flip-flops into the Data pins of a further pair of D-type flip-flops, IC3b and IC4b, which are clocked by the 40MHz oscillator.

The effect is that the Q output of IC3b will not go High until the leading edge of the first oscillator pulse following the Q output of IC3a going High. Similarly, the Q output of IC4b will not go High until the leading edge of the first oscillator pulse following the Q output of IC4b going High.

The time difference between the Q outputs of IC3b and IC4b going High is now longer than the input pulse, but by no more than the resolution of the Pulsometer, but now the pulse is synchronised with the 40MHz clock.

The outputs of IC3b and IC4b are fed into the XOR gate of IC2d, the output at pin 3 being a positive-going pulse representing the mark of the input pulse. The end of this pulse is detected on the PIC's RB1 pin, which is connected to the Q output of IC4b.

Even with the synchronisation described there is still a little instability in the final display. This is because many signals are unstable at the nanosecond level.

To measure the space between two input pulses, the PIC simply reverses the control signals given to IC2a and IC2b, so that IC3a is triggered by the inverted space, and IC4a is triggered by the uninverted mark. To measure the period of a pulse cycle, the PIC causes neither IC2a nor IC2b to act as inverters, so that IC3a is triggered by the leading edge of the input's mark, and IC4a is triggered by the leading edge of the following mark.

GATE AND COUNTER

The circuit diagram for the Gate and Counter is shown in Fig.4. At the start of the measurement cycle, the PIC holds the 14-bit counter IC7 in reset by applying a High to its Clear pin. The PIC also applies a Low to the 3-input NAND gates at pin 11 of IC6a and pin 5 of IC6b, which causes their outputs at pins 8 and 6 to be High.

The PIC also applies a High to pin 1 of IC6c, and because all three inputs to IC6c are High, the output at pin 12 is Low. This is connected to the Clock input of the counter at pin 10.

If frequency is to be measured directly, the PIC releases the reset on the counter's Clear input and places a High on pin 11 of IC6a for one second. The input signal from the Buffer (IC1c) is now allowed through IC6a and IC6c, and hence clocks the counter.

Counter IC7 is a 74HC4020, which is the 4000 series chip in 74HC technology. This is a 14-bit counter, which overflows on the 16,384th input pulse causing output Q14 to go from High to Low. This is detected by the PIC at its RB0 input, and to do this bit 7 of the PIC's OPTION register must be set to 1, which causes negative-going edges rather than positive-going ones to be recognised.

LOGIC HINT 1 Exclusive-OR (XOR) Gates

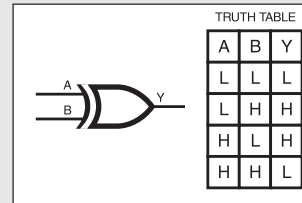

XOR gates give High outputs when, and only when one input is High and the other is Low. They are very versatile and in this project they are used in several different ways:

a. They can produce an output pulse which equals the time difference between two different signals at the input. IC2d is used like this.

b. When one input is tied High, a signal at the other input is inverted, as in IC2c.

c. If one input is connected to a PIC or other control logic, an input signal can be inverted or not depending on whether the control input is High or Low. IC2a and IC2b are controlled in this way.

The PIC counts these overflows in a multi-byte register, and at the end of the cycle multiplies it by 16,384.

For all frequencies below 16,384Hz, and for all higher frequencies which are not multiples of 16,384Hz, there will be a count left in the counter at the end of the one-second pulse. To flush this out of the counter and into the PIC, pin 1 of IC6c is toggled by the PIC's RB5 pin (with pin 11 of IC6a and pin 5 of IC6b held Low) until the counter overflows.

The PIC counts the number of times it toggled the counter, subtracts it from 16,384, and adds the result to the previous count. The final result is that the PIC now has an accurate count of the pulses received in one second. The total count is scaled to the appropriate units and displayed.

PULSE TIME

To time a pulse, the circuit operates in a similar way. At the start of the cycle the PIC releases the reset on the counter and applies a High to pin 5 of IC6b. When the pulse to be timed is received from the Pulse Generator and Synchroniser at pin 3 of IC6b, it will now gate pulses received from IC5, the 40MHz clock. These are counted in exactly the same way as for frequency measurement. The PIC detects when the pulse has finished via its RB1 pin and the Q pin of IC4b.

For timings, the count is multiplied by 25, which gives the total number of nanoseconds. If frequency is to be calculated, the count is divided into 40,000,000.

The use of the three 3-input NAND gates in IC6 is an example of how to minimise the number of chips used in a design, and the principle is shown in Logic Hint 2.

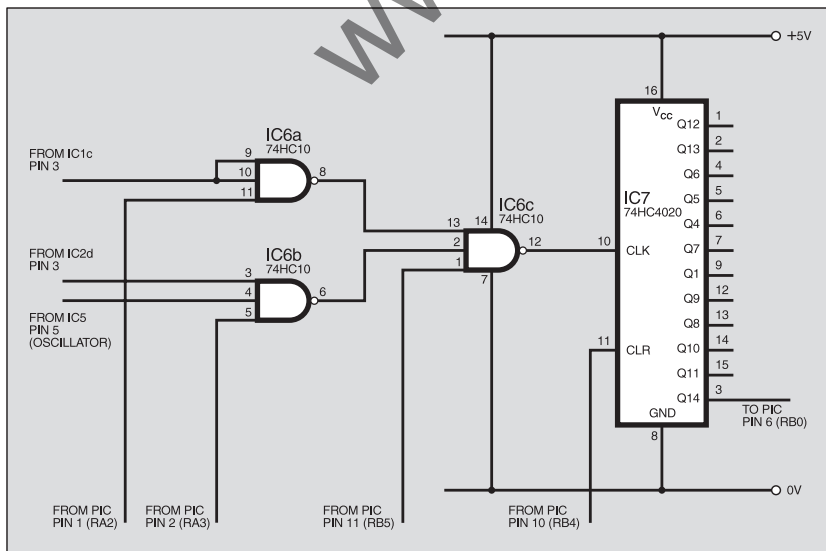

Fig.4. Circuit diagram of the gate and counter sections.

CONTROL AND DISPLAY

The Control and Display circuit diagram is shown in Fig.5. Most of the PIC pins are connected to gates in the other circuits to provide control. The Mode switch S1 is connected to RB7, with R5 as a pull-down resistor. The PIC. RA4 has a pull-up resistor (R6), as this is an open-collector output.

You can see from the diagram that the data lines from the PIC (RA0 to RA3) going to the l.c.d.'s pins D4 to D7 also go to other circuits for control purposes. The reason that the l.c.d. does not show junk on its screen is because the l.c.d. only accepts data or commands when its E pin is High.

As the operation of the meter is cyclic, the PIC holds the E pin Low while it is using RA0 to RA3 to control the circuits, and holds the circuits in reset when it is sending information to the l.c.d. and causing it to be displayed with the E pin.

This is a useful trick to use if you are running out of PIC pins, and can be applied to many designs.

Wonderful devices though they are, l.c.d.s do not have particularly good visibility. A couple of extra pounds were spent equipping the Pulsometer with a back-lit type. This requires 5V to be applied to the separate pins 15 and 16. If you don't want to use a back-lit type, omit the pin 15 and 16 connections.

A 16-character by 1-line display was also used, as these have taller and therefore more readable characters. This requires additional programming as each character uses two l.c.d. addresses. A 2-line display can be used, and the code shows the lines that have to be deleted. Finally, VR1 allows the l.c.d. contrast to be adjusted.

RC OSCILLATOR

The RC Oscillator circuit is shown as part of Fig.2. When capacitance is to be measured, the PIC enables IC1b with a High at pin 5. This causes oscillation at a frequency determined by C1 and R4. Providing there is no signal present at socket SK1, transistor TR1 and IC1a enables IC1c at pin 1. This allows the PIC to measure the period of the pulse train using the techniques described above.

LOGIC HINT 2 – Saving Chips

A problem arose with the Gate and Counter circuit logic which needed to function as shown in the following diagram:

The problem is that 2-input AND gates come four to a chip, and 3-input AND and OR gates come three to a chip. So to use this logic as it stands would require three chips, and leave seven gates unused (unless they are needed elsewhere in the project). This adds size and complexity (and a little cost) to the project.

One way to reduce the problem is to use a 3-input AND gate for IC1, tying two inputs together to make a 2-input gate. However, this still needs two chips with four gates unused.

The following circuit provides a more economical solution:

This performs almost the same function as the first circuit, except that the input F must now be inverted. As this is supplied by the PIC this is easy to arrange without using further gates.

This still uses the same number of gates but they are now of the same type, which has reduced the complexity considerably as only one chip is now required, a triple 3-input NAND gate.

Logic design often requires that several inputs are ANDed in groups, and then the groups are ORed together. This technique can be used to advantage in such situations.

A "test" capacitor can be plugged into socket SK2, altering the frequency and therefore the period. The calculation of the value of test capacitors requires a calibration process. Although Schmitt trigger RC oscillators are not very stable, this design is capable of measuring values of a few picofarads and gives good accuracy at 10pF and above.

The RC oscillator is shown with more detail in Fig.6. In a Schmitt trigger RC oscillator, the period T of the pulse train generated is given by the formula:

$$T = K \times R \times C$$

where K is a constant (at least at reasonable

frequencies) which depends on the switching points of the Schmitt trigger, which will vary from chip to chip.

In addition, the input capacitance of the Schmitt trigger (Ci) and stray capacitance in the circuit (Cs) will give inaccuracies in trying to measure the value of a test capacitor (Ct) directly using the above formula.

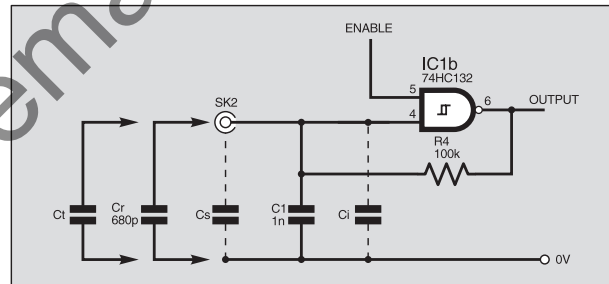

Fig.6. The RC oscillator circuit in more detail.

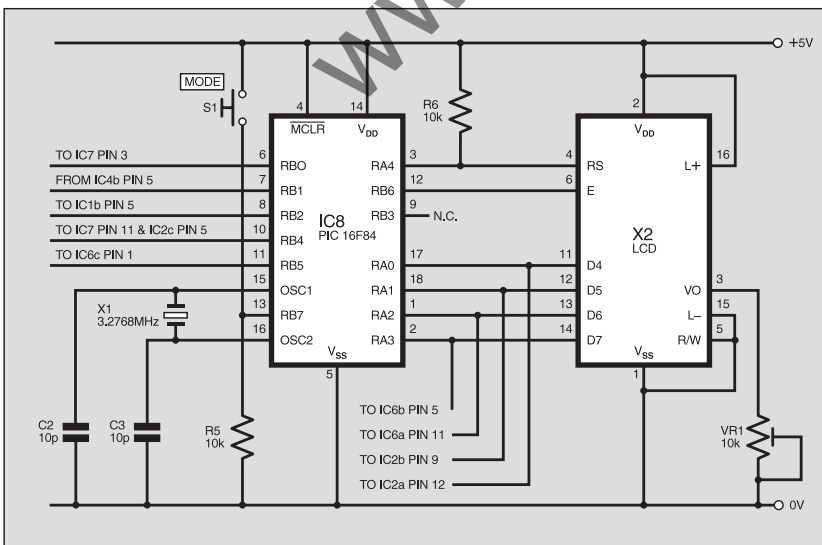

Fig.5. Circuit diagram for the PIC controller and l.c.d. stages.

In the project a calibration step is carried out by inserting a reference capacitor (Cr) into socket SK2. After calibration has been done, a test capacitor can be measured by inserting it into the socket. This gives rise to the following formulae:

$$\begin{aligned} T_o &= K \times R4 \times (C1 + C_s + C_i) \\ T_r &= K \times R4 \times (C1 + C_s + C_i + C_r) \\ T_t &= K \times R4 \times (C1 + C_s + C_i + C_t) \end{aligned}$$

From these the following formula can be derived:

$$C_t = C_r \times (T_t - T_o) / (T_r - T_o)$$

Since the number of pulses N counted by the PIC is directly proportional to the period T of the pulse being measured, the formula becomes:

$$C_t = C_r \times (N_t - N_o) / (N_r - N_o)$$

Like magic, the constant K and the input and stray capacitance have disappeared

from the calculation, and the accuracy of the result now seems to depend only on the accuracy of the reference capacitor (Cr).

In the Pulsometer, calibration is not done every time a capacitor is measured, but infrequently, and the values of No and (Nr - No) are stored in the PIC's EEPROM. When a test capacitor is measured, the temperature will probably be different from when the meter was calibrated, and the values of K, R4, C1, Cs and Ci, upon which No and Nr depend, could all be slightly different.

In the prototype high stability items are used for R4, C1 and Cr, and good accuracy and stability are achieved in practice.

According to the theory it doesn't matter what values R4 and C1 have - the ones used were chosen so that the NAND gate would oscillate linearly over the test capacitance range desired, which is from a few pF up to 999µF.

POWER SUPPLY

The power supply is a conventional circuit and is shown in Fig.7. Power is input via socket SK3 and diode D3, the latter guarding against incorrect polarity. With a backlit l.c.d., around 90mA is drawn, and a 1A 7805 voltage regulator was preferred to the 100mA type. If a non-backlit l.c.d. is being used, a 100mA type can be substituted.

Capacitors C4 to C12 provide power stability. 74HC chips have a very fast switching action, which produces big voltage spikes on the positive supply rail.

Decoupling capacitors C7 to C12 are located as close to the Vcc (+VE) pin of each chip as possible, but are shown here rather than in the circuit diagrams for clarity.

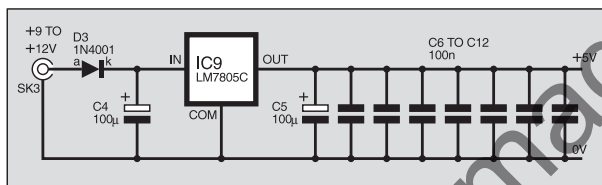

Fig.7. Power supply circuit diagram, including the decoupling capacitors.

CONSTRUCTION

Construction of the PIC Pulsometer is made on stripboard. Stripboard has many advantages for the amateur constructor - no expensive layout software or equipment, no nasty chemicals, and it is easy to modify. On the downside, layouts are physically bigger than with printed circuit boards

(p.c.b.s). However, as part of the following construction details, comments are made on how to minimise stripboard layout size.

The prototype uses a console case made of ABS with an aluminium top. It also has an attractive, rounded sloping front, which improves readability, and is no bigger than it need be.

All of which is to say that construction would have been less fiddly if a slightly bigger, regularly shaped case had been chosen! The constructional notes are based on the one used.

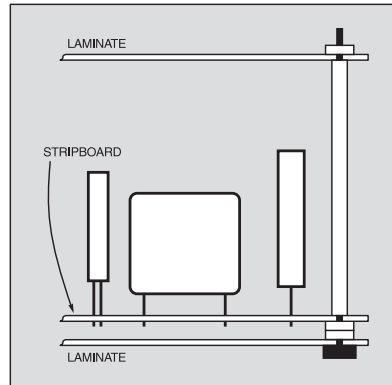

Fig.8. Suggested method of "sandwiching" the stripboard between two pieces of p.c.b. laminate.

The stripboard component layout details and breaks required in the copper tracks are shown in Fig.9.

PREPARATION

First, the stripboard should be prepared by cutting it so that a full 31 rows of 60 holes are available. Stripboard, and the plain p.c.b. laminate also used, may be cut

easily by scoring both sides with a sharp knife and then snapping it. Make the corner cutouts required to allow for the case's corner pillars.

The fixing pillars at the bottom of the case are in the wrong place for the stripboard. This is overcome by making a base of single-sided copper p.c.b. laminate, which is screwed to the case using the self-tapping screws supplied. A similar piece of p.c.b. laminate is also used above the stripboard - see Fig.8.

COMPONENTS

Resistors

- R1 2k2
- R2 2k7
- R3 1M
- R4 100k 1% metal film
- R5, R6 10k (2 off)

All 0.25W 5% carbon film unless stated.

Potentiometer

- VR1 10k carbon preset, min. round

Capacitors

- C1 1000p silvered mica
- C2, C3 10p ceramic 2.5mm pitch (2 off)
- C4, C5 100µ radial elect. 16V (2 off)
- C6 to C12 100n polyester 5mm pitch (7 off)
- C7 680p silvered mica

Semiconductors

- D1, D2 1N4148 signal diode (2 off)
- D3 1N4001 rectifier diode
- TR1 BFY90 npn transistor (see text)
- IC1 74HC132 quad 2-input Schmitt NAND gate
- IC2 74HC86 quad 2-input XOR gate
- IC3, IC4 74HC74 dual D-type flip-flop (2 off)
- IC5 40MHz oscillator module, fitting an 8-pin d.i.l.
- IC6 74HC10 triple 3-input NAND gate
- IC7 74HC4020 14-stage counter
- IC8 PIC16F84 microcontroller, pre-programmed
- IC9 7805 +5V 1A voltage regulator (see text)

Miscellaneous

- SK1 BNC socket
- SK2 20-pin d.i.l. socket (stamped pin)
- SK3 2.1mm power socket
- S1 s.p. pushswitch, break-before-make
- X1 3.2768MHz crystal
- X2 l.c.d., 16-char x 1-Line backlit l.c.d.

Stripboard, 31 rows x 60 holes; stripboard 16 rows x 8 holes; single-sided p.c.b. laminate (see text); 8-pin d.i.l. socket; 14-pin d.i.l. socket (5 off); 16-pin d.i.l. socket; 18-pin d.i.l. socket (turned pin); BNC plug; 12.5mm metal stand-off (4 off); case to suit; connecting wire; coax cable; 6BA nut (8 off); 6BA 12.5mm bolt (8 off); 3mm nut (12 off); 20mm x 3mm bolt (4 off); solder, etc.

Approx. Cost
Guidance Only

£38
excl. case

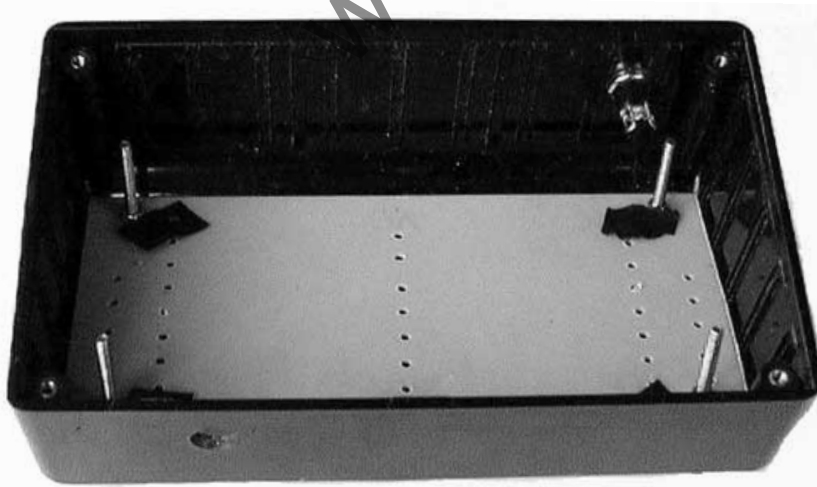

Interior of the case showing the bottom p.c.b. laminate piece (copper-side down) and circuit board mounting bolts. Note the rows of vent holes.

Cut the bottom piece of laminate to the same size as the stripboard, and drill 4mm holes for the self-tapping screws. Check that it will fit into the box, but do not fit in place yet.

The top piece of laminate should be cut slightly smaller than the stripboard along the back and sides. This is to allow the hook up wires to pass.

Clamp the three boards together with the stripboard on top and the laminate boards copper side down, and drill the four 3mm mounting holes.

TABLE 1 Solder Pin Connections

| | |
|-----------------------------------|-------------------------------------|
| P1 I.c.d. VSS pin 1 | P10 I.c.d. D7 pin 14 |
| P2 I.c.d. V0 pin 3 | P11 I.c.d. D6 pin 13 |
| P3 I.c.d. VDD pin 2 and switch S1 | P12 I.c.d. D5 pin 12 |
| P4 I.c.d. backlight 0V pin 15 | P13 I.c.d. D4 pin 11 |
| P5 I.c.d. backlight +VE pin 16 | P14 SK2 +VE side |
| P6 I.c.d. R/W pin 5 | P15 SK1 centre pin |
| P7 I.c.d. E pin 6 | P16 SK1 0V (screen) and SK2 0V side |
| P8 switch S1 | P17 SK3 0V } power input |
| P9 I.c.d. RS pin 4 | P18 SK3 +VE } (+9V to +12V) |

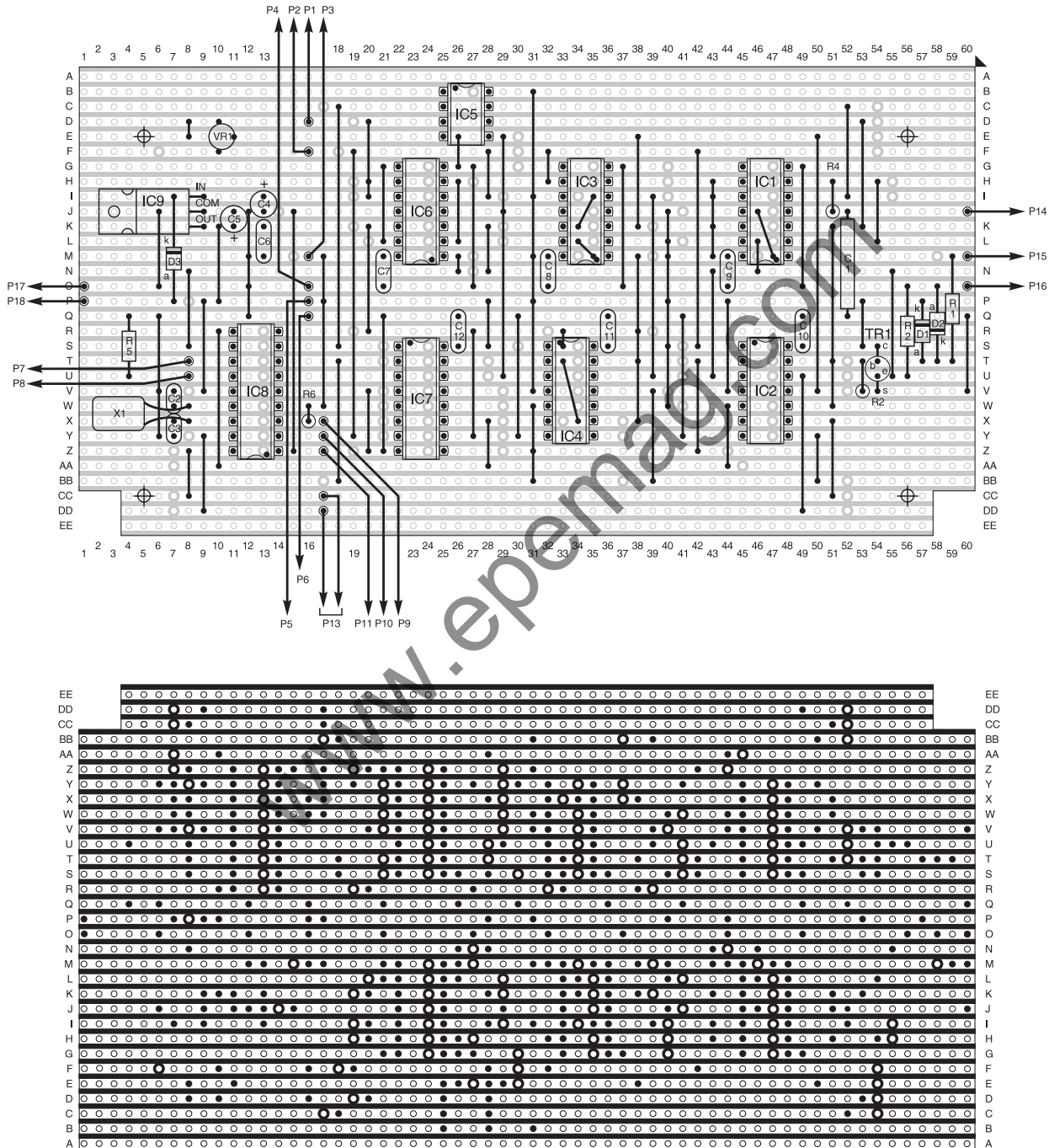

Fig.9. PIC Pulsometer stripboard component layout and details of breaks required in the underside copper tracks. Note some link wires are made from thin 26 s.w.g. or 28 s.w.g. wire to allow two wires to go into the same hole – see text.

Although the circuit does not give out a lot of heat, there is no ventilation, so drill a series of holes through both the top and bottom laminate boards. Make sure there are plenty on the side where the regulator is situated, and on the other side where C1 is placed. Also drill a line of holes along the top of the back of the box, but below the lip where the top sits.

The holes for the BNC socket (SK1) and the power socket (SK3) should be drilled towards the top edges of the box so that they will not foul the top piece of laminate when fitted.

Insert 20mm x 3mm bolts from the copper side of the bottom board, secure them with two nuts each, and screw it into the box, covering the screws with insulating tape.

Using the holes in the laminate as a guide, drill through it to make an identical set in the bottom of the box.

Ream, or drill out the bolt holes in the stripboard and top laminate to be a loose fit over the bolts. Check that you can reasonably easily fit the boards into the box and get them out again!

BOARD NOTES

Another downside of stripboard is creating the layout – it hurts the brain! The author failed to buy a product called Stripboard Magic a few years ago and has regretted it ever since, as the supplier has now gone out of business. It would be interesting to know how it would have got on with this – perhaps any readers out there with a copy would like to give it a go and report the result . . . ?

Although the reverse side of the stripboard is shown, the author prefers to mark the top side of the board with a fine permanent marker where holes in the track underneath have to be cut, and then poke the end of a resistor through to show where the cut has to be made. Not very quick, but very sure!

When cutting the track holes, make sure that no copper edge is left and, after all the holes have been cut, the board should be thoroughly checked, deoxidised and degreased – a p.c.b. polishing block makes a good job of this.

Two techniques are used to reduce the physical size of the layout. The first is the common one of placing links underneath the chips. The second is less common and allows “runs” of connections to use the same “column” of the stripboard – see, for example, the connections made at rows B, I, M, P and V of column 31.

For this to work, thinnish tinned copper wire is needed in order to get two wires into the same hole. The 32swg gauge wire used in the prototype is rather fiddly and 26 or 28swg would be better.

Any attempt to use either insulated wire, or sleeving, will probably drive you completely mad. If the links are reasonably taught then problems are unlikely to occur.

ASSEMBLY

Populate the board with the components (except the i.c.s), starting with the links.

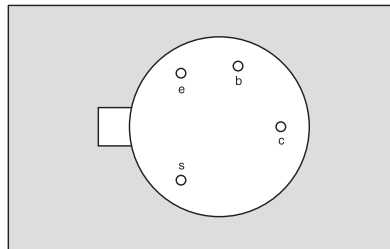
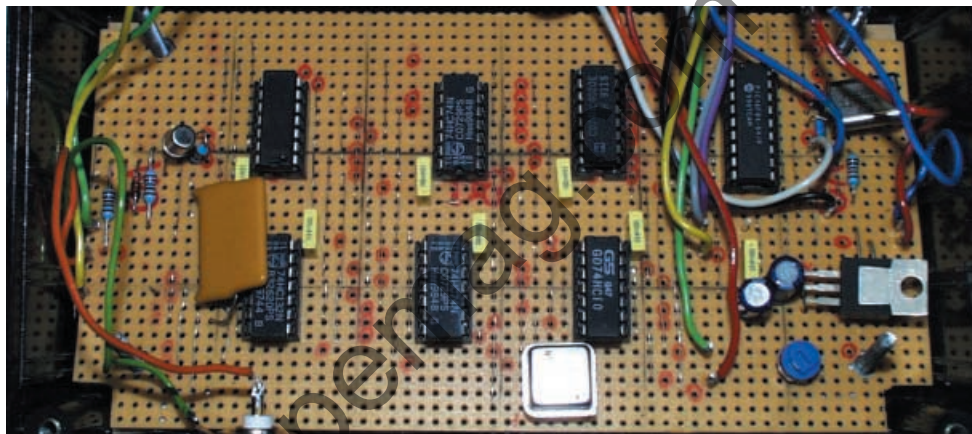

Fig.10. Pinout details (pin view) for the BFY90 transistor. The lead marked S is the screen.

After the links have been soldered in place, check that they all exist and go between the right holes. The remaining components are then mounted in order of increasing height.

Dual-in-line (d.i.l.) sockets should be used for all i.c.s. (including the 40MHz oscillator IC5). Preferably use a turned-pin socket for the PIC, IC8. Make sure the sockets are inserted with the notch pointing the right way.

The leads of crystal X1 and regulator IC9 need to be bent so that the components lie parallel to the surface of the board.



Layout of components on the completed prototype circuit board.

Transistor TR1 has four leads (the fourth being the shield). Its pinout is shown in Fig.10. This is mounted in-line, and so the leads need to be bent carefully to match the holes on the stripboard, taking care they do not short each other.

After soldering, inspect the board through a magnifying glass for solder bridges and splashes. Because the flux that flows into the channels between the tracks can sometimes shine like solder, it helps to clean them out first by running the corner of a small screwdriver blade along the channels.

The requirements are tough for socket SK2, into which capacitors are plugged for measurement. Capacitors come with lead spacings from 2.5mm upwards, and with lead thicknesses of varying sizes. There is probably not an ideal solution, but a reasonable one is to use a 20-pin d.i.l. socket, which must be of the stamped pin variety.

This is mounted on a small piece of stripboard of 16 rows by 8 holes, with wires soldered along the track side so that pins 1 to 5 and 16 to 20 are connected together, and pins 6 to 15 are connected together, see Fig.11.

The holes in the corners for the mounting bolts should be isolated from the d.i.l.

socket as connecting the top cover to 0V messes up capacitance measurement. Two solder pins mounted from the copper track side of the board provide connections for the hook-up wires.

The d.i.l. sockets have connections that are springy enough to hold thin leads, but will also accept fat ones. After a while the fat leads will destroy the springiness of a particular socket pin, so it is a good idea to reserve pins for particular kinds of leads.

TESTING

Off-board connection points are tabulated in Table 1.

First apply a 9V to 12V supply via solder (terminal) pins P17 and P18. Test the output of the regulator and the Vcc/Vdd (+VE) pins of all d.i.l. sockets for +5V. Do the same for 0V at the GND/Vss pins. Any fault at this stage must be found and corrected.

Remove the supply and attach the l.c.d. to the appropriate solder pins. The usual hook-up wire is a bit thick and the author prefers to use wire stripped from a ribbon cable. Make the wires long enough to reach from the bottom of the case and over the back to the work-table surface.

Insert a pre-programmed PIC16F84 (NOT a PIC16C84) into its socket, making sure the notches line up. If you are programming the PIC yourself, the PIC should be configured for an XT (100kHz to 4MHz) crystal, with the watchdog timer disabled, and the power-up timer enabled.

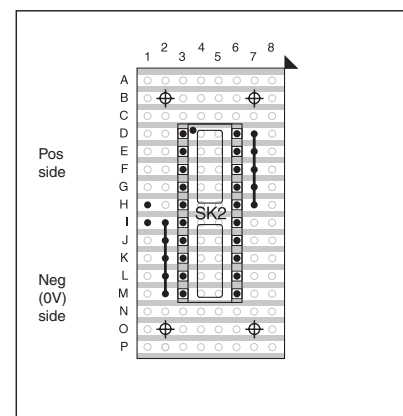

Fig.11. capacitor “test” socket SK2 is mounted on a piece of stripboard, which is bolted to the case lid.

If the power supply is now reconnected, the l.c.d. should look like Fig.12a. It will probably be necessary to adjust the contrast with VR1. With the power removed the remaining chips can now be installed, correctly orientated.

The 40MHz oscillator (IC5) has a spot on the metal case above pin 1, and its leads may need to be trimmed a little so that it fits snugly into its d.i.l. socket.

Except for capacitance measurement, the functions can be tested at this stage by reconnecting the power and applying a suitable signal to the input pins. If you have not got a signal generator, an RC oscillator can be assembled in the same fashion as that around IC1b, using a breadboard and a spare Schmitt trigger chip. The l.c.d. should show a display similar to that in Fig.12b.

If solder pin P8 is connected briefly to solder pin P3, the PIC will change mode each time and displays such as those in Figs.12c to Fig.12f should be obtained. If selected, the capacitance mode may display rubbish at this point, as meter has not yet been calibrated.

TOP PANEL

The top panel is aluminium, not ABS (does anyone like working with ABS?). The rectangular holes for the l.c.d. and 20-pin d.i.l. socket (SK2) are made in the time-honoured way of drilling holes round the edges and filing down.

Drill the hole for switch S1, and the fixing holes for the l.c.d. and SK2 sub-assembly.

If, like the author, you are unable to produce perfectly straight and square edges, then model a template on a computer. Print it out on thin card, make the cutouts with a scalpel, protect the card with a spray coating sold by stationers for this purpose, and fix to the plate with glue.

For best effect the cutouts in the panel need to be very slightly bigger than the card cover. With this technique colouring and lettering from a wide range of fonts can be added, all perfectly aligned.

ASSEMBLY

Assembly is straightforward. First mount the l.c.d., SK2 sub-assembly and switch S1 on to the top panel. Size 6BA nickel-plated bolts give a good appearance, and their full nuts make the d.i.l. socket sit flush with the panel.

Solder the remaining hook-up wires to the solder pins on the stripboard. As there are 18 wires it is best to label them carefully as their connection to the stripboard cannot be seen when it is mounted in the case.

Bend the large capacitor C1 over a little so that nothing on the board rises more than 12.5mm above the surface and mount the stripboard on to the 20mm bolts in the case, with 12.5mm metal spacers on top. These must be metal as one of them forms a 0V link between the two p.c.b. laminates and the stripboard.

Feed all the wires over the back of the case, except those from solder pins 14, 15, 16, 17 and 18, which feed over their respective sides. Gently press them down to follow the contours of the stripboard and case, and fix the top p.c.b. laminate, copper side down, on to the 20mm bolts. The BNC and power sockets can now be fitted.



Fig.12a. Display on power-up.



Fig.12b. High frequency measure-



Fig.12c. Low frequency measurement.



Fig.12d. Period measurement.

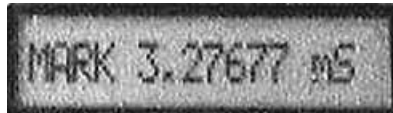

Fig.12e. Period measurement.

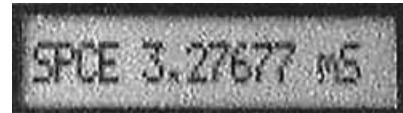

Fig.12f. Period measurement.

Finally, trim the remaining hook-up wires to length and solder to the sockets and switch S1.

An oscilloscope probe can be used with the Pulsometer or, failing that, make one up from a BNC plug, coax cable and probes or crocodile clips at the other end.

OPERATION

The meter does not have an on/off switch – it starts working when plugged in. Any 9V to 12V d.c. mains adaptor supply should be suitable. Nor is there a reset button. It is a brave programmer who claims not to have any bugs in their code, but the author has not found any since completing the project. However, if the PIC gets confused, reset by interrupting the power supply.

You have probably played with the meter during the testing stage, but the following is a complete description of its functions.

At first power-up the screen in Fig.12a is

displayed, stating that the meter is in the higher frequency mode, F(H). This measures frequency to the nearest Hertz, rounded down.

The display removes leading zeros but not trailing ones, and is scaled to the appropriate units. The display is refreshed every second. Try the meter out at higher and lower frequencies.

Mode is selected by using the pushbutton switch S1. The first push brings the lower frequency mode. When no signal is present on first use of the mode the measurement and units area will remain blank. This is not an error – the meter is waiting to be triggered by the leading edge of an input pulse. Try it out on the same frequencies as before and notice the difference.

It will be seen that if the input signal is removed, the last measurement made will continue to be displayed until either a new signal is input, or the mode is switched.

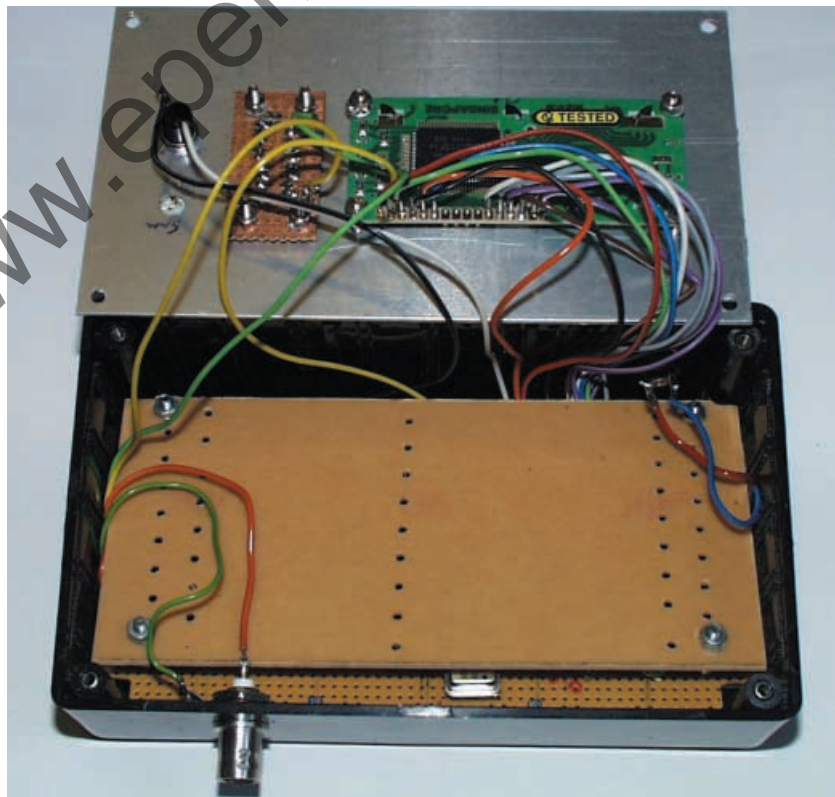

Completed unit showing wiring to the Mode switch, "test" socket and l.c.d. module bolted to the rear of the case lid.

The point where one mode is more accurate than the other is approximately 6324Hz – this being the square root of the 40MHz clock frequency.

Further pushing of the switch brings the Period, Mark and Space modes. These have the same characteristics as the lower frequency mode. The maximum time that can be measured is just over 1.9 hours (which is shown in seconds).

Should this time be exceeded the letter "O" (meaning overflow) will appear in the next available character on the screen. No reset is necessary – it will disappear of its own accord when the next input below this limit is measured.

The time taken to display the result depends on the time of the Period, Mark or Space being measured, but the meter is slugged so that the display is never updated more frequently than about once a second.

The Pulsometer's clock has a period of 25ns, which means that Period, Mark and Space (and lower frequency) measurement become increasingly accurate as the pulse time gets longer or the frequency lower.

CALIBRATION

A final push of the switch will bring up the capacitance measurement mode. Until calibration has been done, the display may show zero or any random value.

For accuracy, the Pulsometer should be allowed to reach normal working temperature by leaving it switched on for 10 minutes or so, before either measurement or calibration is performed. No signal should be present at the input BNC socket during either calibration or capacitance measurement, as this will confuse the meter.

Calibration mode can be entered from any other mode by pressing and holding the pushswitch for several seconds, and then releasing it as soon as the message appears (see Fig.13a). This cryptic message is the downside of using a 1-line display!

A precision, low temperature coefficient 680pF capacitor should now be plugged into the 20-pin "test" socket SK2, with one lead going to the top half, and the other to the bottom half. A silvered mica one per cent type with the leads trimmed short was used for the prototype.

The switch is then pushed, when the capacitance display will appear, as in Fig.13b. This should show a value very close to 680pF, and the display may vary every second by up to 1pF either way.

CAPACITORS

Capacitors may now be measured by plugging them into SK2. Measurement is very accurate for capacitors of 100pF upwards, when tested with one per cent capacitors. Readings between 10pF and 99pF appear to be accurate, although they were tested using only 10 per cent capacitors. Useful indications are given as low as 1.8pF. See Fig.13c to Fig.13e.

Measurement is disabled above 999uF – these take around two minutes to measure, which seems long enough. Electrolytics and tantalums must be inserted into the d.i.l. socket (SK2) with the correct polarity.

If the capacitance to be measured does not plug into the socket, stick a couple of wires, with clips or probes at one end, into the d.i.l. socket. This will affect the calibration, which can be compensated for by



Finished PIC Pulsometer showing front panel display cutout and the 20-way d.i.l. socket for testing capacitors. The top half of the socket has been painted red to identify the "positive" side.

measuring the offset given by the 680pF capacitor, or by recalibrating.

It is not necessary to recalibrate if power is removed from the meter, as the calibration values are stored in the PIC's (non-volatile) EEPROM. Calibration can be checked at any time simply by measuring the 680pF capacitor.

Variations of a few pF will be because of temperature differences, so if precise



Fig.13a. Calibration message.



Fig.13b. After calibration.



Fig.13c. Display for a 1.8pF 10 per cent capacitor.

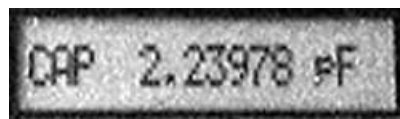

Fig.13d. Display for a 2.2pF 10 per cent capacitor.



Fig.13e. Display for a 100nF 10 per cent capacitor.

measurement, or measurement of small capacitors is required, the meter should be allowed to reach working temperature and the ambient temperature should be similar to that when the meter was calibrated. If the reading for the 680pF capacitor is not close to that value, then recalibrate.

POWERING OFF

No "brown-out" detection is included in this design, and so the meter should not be powered down in calibration mode. If this is done and a brown-out occurs, the calibration values in the EEPROM may be incorrect. If this happens, simply recalibrate.

PROGRAM

The program occupies almost the whole of the code area, and it is not appropriate to describe it in detail here. The software is available on 3.5-inch disk from the Editorial office (a small handling charge applies), or free from the EPE web site. See this month's *Shoptalk* page for more details.

The code is by no means perfect in that some code space could be saved by greater use of subroutines in some instances. Working on the principle that "if it ain't broke don't fix it", the author decided not to make these cosmetic alterations.

The Pulsometer uses some multi-byte registers to do its arithmetic – three 5-byte ones for binary working and two 13-byte ones for BCD. The PIC's instruction set has some limitations which make handling such registers tedious (no store-to-store instructions, and only one indirect addressing register). The Pulsometer's source code illustrates some useful techniques.

In calculating lower frequencies, and for the capacitance calculations, adding and subtracting big integers in long registers is required, as is multiplication and division of fractions. The latter use a form of floating point arithmetic, although the division subroutine is slightly less accurate than the best. This was done for space reasons, and is accurate enough for the project.

Finally, there are subroutines for converting big numbers from binary to BCD. □