

Copyright © 2008, Wimborne Publishing Ltd
(Sequoia House, 398a Ringwood Road, Ferndown, Dorset BH22 9AU, UK)
and TechBites Interactive Inc.,
(PO Box 857, Madison, Alabama 35758, USA)

All rights reserved.

The materials and works contained within EPE Online — which are made available by Wimborne Publishing Ltd and TechBites Interactive Inc — are copyrighted.

TechBites Interactive Inc and Wimborne Publishing Ltd have used their best efforts in preparing these materials and works. However, TechBites Interactive Inc and Wimborne Publishing Ltd make no warranties of any kind, expressed or implied, with regard to the documentation or data contained herein, and specifically disclaim, without limitation, any implied warranties of merchantability and fitness for a particular purpose.

Because of possible variances in the quality and condition of materials and workmanship used by readers, EPE Online, its publishers and agents disclaim any responsibility for the safe and proper functioning of reader-constructed projects based on or from information published in these materials and works.

In no event shall TechBites Interactive Inc or Wimborne Publishing Ltd be responsible or liable for any loss of profit or any other commercial damages, including but not limited to special, incidental, consequential, or any other damages in connection with or arising out of furnishing, performance, or use of these materials and works.

READERS' TECHNICAL ENQUIRIES

We are unable to offer any advice on the use, purchase, repair or modification of commercial equipment or the incorporation or modification of designs published in the magazine. We regret that we cannot provide data or answer queries on articles or projects that are more than five years' old. We are not able to answer technical queries on the phone.

PROJECTS AND CIRCUITS

All reasonable precautions are taken to ensure that the advice and data given to readers is reliable. We cannot, however, guarantee it and we cannot accept legal responsibility for it. A number of projects and circuits published in EPE employ voltages that can be lethal. You should not build, test, modify or renovate any item of mains-powered equipment unless you fully understand the safety aspects involved and you use an RCD adaptor.

COMPONENT SUPPLIES

We do not supply electronic components or kits for building the projects featured; these can be supplied by advertisers in our publication Practical Everyday Electronics. Our web site is located at www.epemag.com

We advise readers to check that all parts are still available before commencing any project.



To order your copy for only \$18.95 for 12 issues go to www.epemag.com

Constructional Project

PIC-GEN FREQUENCY GENERATOR/ COUNTER by JOHN BECKER

Add even more versatility to your workshop facilities.

Combining the sophisticated features of a Maxim MAX038 waveform generator and a PIC16F877 microcontroller has resulted in a highly versatile and inexpensive workshop tool whose facilities have hitherto been unattainable without considerable design complexity.

The MAX038 is a high-frequency precision function generator whose output is selectable to produce triangle, sine and square waveforms, within a wide operating frequency span of 0.1Hz to over 10MHz, split in the PIC-Gen as eight overlapping frequency ranges. Range and waveform selection are performed by the PIC16F877 in response to pushbutton switch controls. Frequency is fully variable within the selected range by means of a front panel control potentiometer.

An alphanumeric liquid crystal module displays the frequency and range information.

Four frequency outputs are provided:

- o) Direct output at $\pm 1V$ peak-to-peak
- o) AC coupled output, fully variable between zero and 4V peak-to-peak
- o) Pulse output, 0V to 5V logic level
- o) 3.2768MHz fixed frequency, 0V to 5V logic level

The PIC is also used as a frequency counter, switch selectable to monitor the frequency generated by the MAX038, or from an external source in conjunction with a pre-conditioning waveform shaper and frequency divider. Two external signal inputs are provided: one for 0V to 5V logic level waveforms, the other for AC waveforms having a peak-to-peak swing of between about 2V to 5V. The prototype can monitor frequencies in excess of 40MHz.

MAX038 FUNCTION GENERATOR

In *EPE* September '96, Andy Flind first introduced readers to the merits of the then newly introduced MAX038 waveform generator, in a special feature article of the same name. He followed it up with a full constructional article, the *10MHz Function Generator*, in October '96.

Prior to the introduction of the MAX038, arguably the main contender for the most widely used function generator was the 8038, manufactured by various companies under different prefix codings, such as ICL8038 and XR8038, for instance.

The 8038 is still widely used but it has limitations in the maximum frequency that can be generated. The range is typically 0.001Hz to 100kHz.

The MAX038, however, is stated to have an upper frequency limit of at least 20MHz, and possibly around 40MHz. It has to be said, though, that attaining such high frequencies requires printed circuit board design and construction techniques normally found only in commercial manufacturing establishments.

The upper frequency limit of the device is dependent not only on very accurate control of the current flowing into its frequency setting inputs, but also on the capacitance associated with them. Maxim state in their data sheet, for instance, that the



specified upper frequency limit is achieved when the timing capacitance is less than or equal to 15pF and the control current is 500uA.

Unfortunately, on a PCB designed for successful assembly by the average hobbyist, the capacitance between the MAX038, other components and the tracks is likely to prevent the maximum frequency from being reached. The prototype PIC-Gen described here achieves a maximum of just over 10MHz.

PIC-GEN CONCEPT

Considering how the MAX038 might be put under semi-automatic control as part of a frequency generator and counter system, the author recognized that a PIC16F877 microcontroller might provide the key. This device has five input-output ports which, it seemed, could possibly provide automated switching of the frequency range capacitors, selection of the waveform shape, offer frequency counting and provide an output to a liquid crystal display.

Doing a basic mock-up on stripboard coupled to a PIC roughly programmed to perform the bare essentials proved the viability of the idea. The concept was then given full flesh and bones to become the design whose circuit diagram is given in Fig.1.

The MAX038 function generator is shown as IC2. It will be seen that half the pins are grounded and from some of their notations it will probably be (correctly) deduced that the device has more functions than are used here. For information about the device's full range of functions, see its data sheet (details later) or Andy Flind's

Sept/Oct '96 articles.

In the PIC-Gen design, the controls used are those that set frequency and waveform shape. The eight frequency ranges are set according to the capacitance value connected to the device's C OSC pin. Fine tuning of the frequency is performed by varying the current provided by potentiometer VR1 to the I IN pin.

Resistor R2 limits the maximum current that can flow, while R1 sets the minimum current.

FREQUENCY SELECTION

Eight capacitors are used to set the frequency ranges, C11 to C18. These are commonly connected at one end to the C OSC pin (5). Capacitors C12 to C18 have their other ends connected individually to port pins of the PIC microcontroller, IC5. For PCB layout convenience these pins were chosen to be RB1 to RB5, RD6 and RD7. Capacitor C11 is permanently connected to the 0V line.

Normally, the above seven pins are set as inputs to the PIC. In this condition, they are effectively held in an open-circuit state, the PIC inputs having a very high impedance. As such, the MAX038 ignores those capacitors.

To bring one of the seven port controlled capacitors into circuit, the PIC has the appropriate pin set as an output held at logic 0 (0V). With a higher capacitance value selected, so the lower the output frequency from IC2.

For the highest frequency range, capacitor C11 is the controlling component. Note, though, that its nominal value of

10pF will be seen by the MAX038 as a value higher than this due to the (unpredictable) capacitance of the circuit in proximity to the C OSC pin. Capacitor C11 could be omitted if you want to try increasing the maximum frequency attainable.

Pushbutton switches S1 and S2 cause the PIC to step the frequency range down or up (respectively) on a continuous 8-step loop.

Nominally, the capacitor values have been chosen to provide a factor of ten difference between each step. Normal manufacturing tolerances apply to these values, especially with the electrolytic capacitors.

Potentiometer VR1 provides a frequency control range of about 1 to 50. For example, if the minimum current flow through VR1 and R2 causes a frequency of 1kHz, then maximum current flow will cause 50kHz to be generated. The range may be shortened by increasing the value of R1, although this will raise the lowest frequency that can be attained.

WAVEFORM SELECTION

PIC-Gen provides selection of three waveform shapes, Sine, Triangle and Square.

Selection is made according to the binary code placed on the MAX038's A0 and A1 inputs. The code is controlled by the PIC, via its RB6 and RB7 pins, as follows:

A1	A0	WAVEFORM
0	0	Square
0	1	Triangle
1	x	Sine

where x = don't care

Pushbutton switch S4 causes the PIC to step through the three waveform codes on a repeating

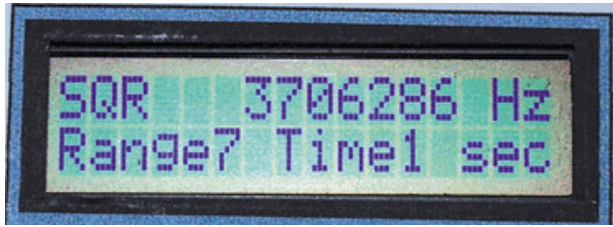

Typical LCD display showing that a square wave is being generated and that a frequency count of 3,706,286Hz has been read on range 7 during the normal 1-second sampling period.

cycle.

The selected waveform is output at IC2 pin OUT and has a fixed amplitude of $\pm 1V$, symmetrical about 0V. The output has a very low impedance (typically $0-1\Omega$) and can be used directly via socket SK5.

The same waveform is amplified by the non-inverting opamp circuit around IC3a. The gain is set at $\times 2$, resulting in an output swing of $\pm 2V$. Capacitor C3 provides DC isolation of the output and potentiometer VR2 provides full control over the amplitude output at socket SK3, from zero to maximum.

It should be noted that the TL082 used as IC3a does not permit the full frequency range of the MAX038 to be amplified and output. In the prototype, a maximum of about 1MHz is experienced, after which the amplitude progressively falls. Other opamps which have higher frequency capabilities are available but no recommendation is offered on this point.

Readers should be aware that whilst some opamps may seem to offer very high frequency capabilities according to their data sheets, other factors (also quoted) can affect the range and must be taken into account.

FREQUENCY COUNTER

Whilst a PIC can be programmed to act as a frequency counter simply by monitoring one input pin, the maximum frequency that can be monitored by this method is severely limited. To enable very high frequency signals to be counted by the PIC-Gen, a pre-counter is used and the output from that is monitored at regular, but slower intervals.

The pre-counter is IC6, a 74HC4040 12-stage ripple counter. Its outputs are fed into PIC pins RC0 to RC7 and RD0 to RD3. It will be seen in Fig.1 that the PIC's pin order use relative to the output pin order of the counter does not match. This is intentional to simplify the PCB design, allowing software to interpret the input values as correct binary numbers.

Note that IC6's Q12 output is the final one in its counting sequence. This changes state at $1/4096$ of the input frequency and even at high input rates the PIC is able to monitor this pin. Each time the pin changes state, the PIC registers the fact and increments an internal counter.

At regular intervals, selectable for one or ten seconds by switch S3 (Sample Time), the full 12-pin sequence of IC6's outputs is read and a frequency value calculated according to this value and that of the internal counter. Once the reading has been taken, the internal and IC6 counters are reset (the latter via PIC pin RD4) prior to the next batch of counting.

Frequencies in excess of 40MHz have been recorded on the author's prototype.

FREQUENCY INPUT

There are three sources from which the signal to be counted can be input, as described presently. All three finally arrive at counter IC6 via the Schmitt trigger NAND gate IC7a. Immediately prior to reading the contents of IC6, the PIC sets pin RD5 low, so turning off gate IC7a and preventing further input signals from



PIC-Gen front panel. The waveform button is bottom far right. The switch marked "pulse" (top right) is the on/off switch in the final model.

Constructional Project

reaching the counter. This allows the ripple-nature of the counter to stabilize (ripple through) at the correct count value. Software introduces a slight delay between closing the gate and taking the reading.

Logic level signals (nominally 0V to 5V) are input to the PIC-Gen via socket SK1 (Logic Input), switch S5 selecting their routing to gate IC7a and the counter. Signals having other voltage ranges,

either above or below the 0V/5V range should not be input to socket SK1. Those having lesser swings may not trigger gate IC7a, those having swings greater than about 6V could kill it.

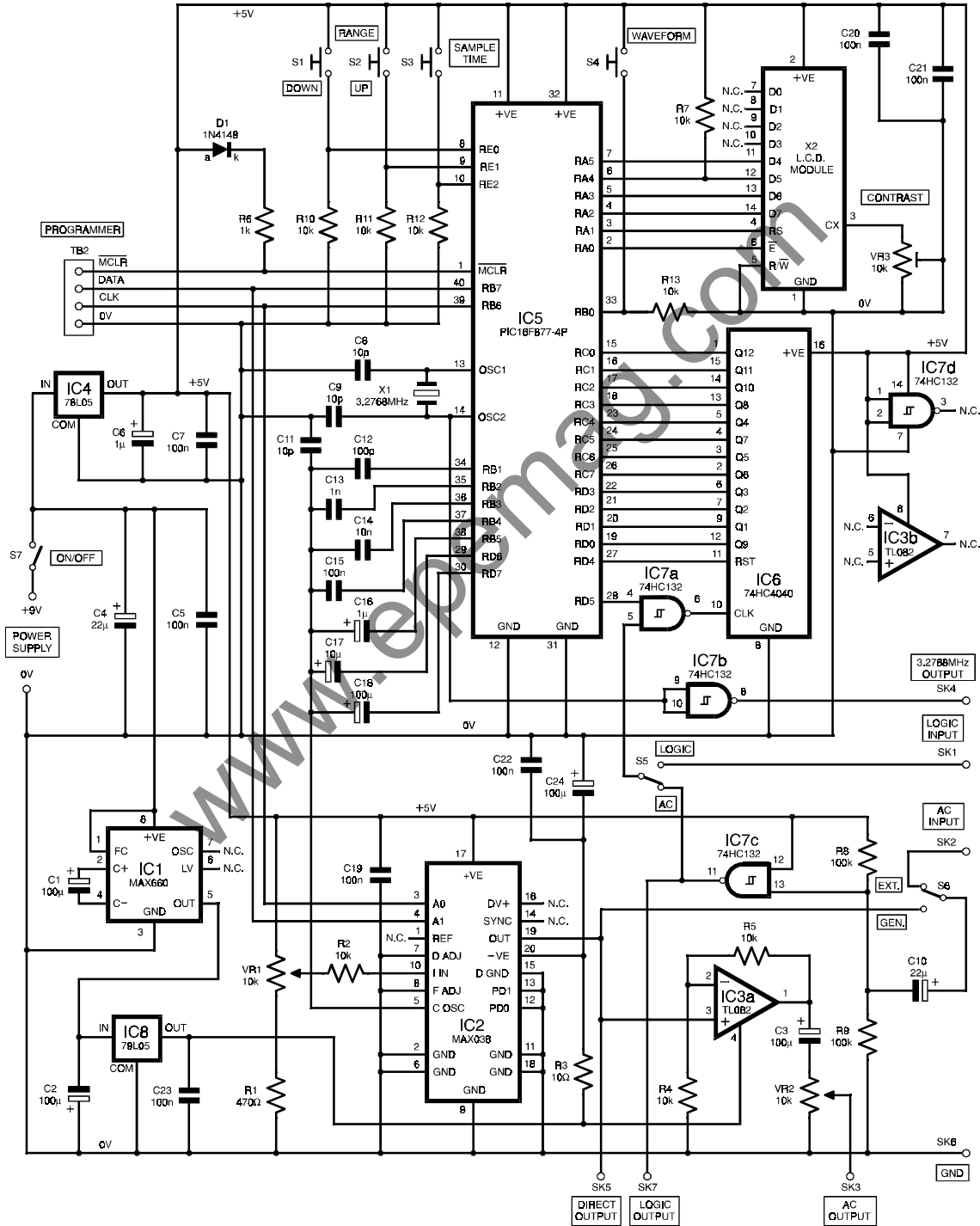

Fig.1. Full circuit diagram for the PIC-Gen Frequency generator and Counter.

Signals which are analog or digital and have a swing range less than 5V, but greater than about 2V to 2.5V, are input via socket SK2 (AC Input). Switch S6 selects their routing to the pre-conditioning circuit around IC7c. This is another Schmitt trigger NAND gate, having one input (pin 13) held biased at a mid-power line level (2.5V) by the potential divider formed by resistors R8 and R9. The other input (pin 12) is held at +5V.

The input signal is AC coupled via C10 to the biased input of the gate. Providing the input signal's peak-to-peak range is greater than the gate's hysteresis value (which varies slightly between individual devices), so the gate will be triggered.

The output of this gate is also fed to switch S5, which routes it to the counter via IC7a when selected.

Because the main output signal from the MAX038 has a peak-to-peak swing of $\pm 1V$, it too has to be pre-conditioned via IC7c before its frequency can be counted, the routing also being selected by switches S6 and S5, respectively.

LOGIC OUTPUT

The output from IC7c is additionally fed to socket SK7 allowing, for example, the frequency generated by the MAX038 to be used as a 5V square wave (irrespective of which waveform is being generated), or for the a.c. signal to be converted to 5V pulses (whose width depends on the nature of the signal).

Whilst the MAX038 has its own 5V square wave available at the SYNC pin (when pin +DV is held high), it was found that



This display shows a sine wave is being generated and a frequency of 25,124Hz has been registered via range 4.

instability occurred when this was generated (as cautioned in Maxim's data sheet). Consequently, the option to use this output has been dropped from the published PIC-Gen (although the connection tracks on the PCB have been retained).

3-2768MHz OUTPUT

The PIC is run at a frequency of 3-2768MHz, as set by crystal X1. Although this frequency can be tapped directly from PIC pin OSC2, it was deemed better to buffer it via gate IC7b before releasing it to the outside world through socket SK4. The output is a 5V square wave.

DISPLAY MODULE

As is common with so many recent *EPE Online* PIC projects, an alphanumeric liquid crystal display (LCD) is used. This shows the frequency count and sampling rate, plus the generated waveform selected and its frequency range (as a number between 0 and 7, where 0 is the lower frequency range). The information displayed takes a form similar to:

SINE 25124Hz
Range4 Time1 sec

where:

- o) Line 1 left: waveform

selected (sine, triangle or square).

- o) Line 1 mid/right: frequency value.

- o) Line 2 left: frequency range selected (8 choices).

- o) Line 2 mid/right: sampling range selected (2 choices).

The LCD is shown as X2 in Fig.1. It is under standard 4-bit control, but whereas many PIC projects control it via PIC Port B, here it is controlled via Port A (RA0 to RA5). Apart from the change of PIC port register number, the software routine that drives the LCD is the author's usual "library" routine.

It is worth noting, though, that because Port A RA4 is an open-collector pin, resistor R7 has to be used to bias it high in order to correctly control LCD pin D5.

The LCD screen contrast is adjustable by preset VR3.

POWER SUPPLY

It is intended that the PIC-Gen should be powered at 9V, either from a 9V battery or a 9V mains power supply (in fact, input supply voltages between about 7V and 12V are acceptable). Regulator IC5 drops and stabilizes the input supply at 5V. This powers IC3, IC5 to IC7, and the LCD. These devices must not be powered

COMPONENTS

Resistors

R1 470 ohms
 R2, R4, R5, R7, R10 to R13 10k (8 off)
 R3 10 ohms
 R6 1k
 R8, R9 100k (2 off)

See also the
SHOP TALK Page!

Potentiometers

VR1 10k panel mounting rotary
 or multi-turn linear (see text)
 VR2 10k panel mounting rotary lin.
 VR3 10k miniature preset, round

Capacitors

C1 to C3, C18 to C24 100u radial
 electrolytic, 16V (5 off)
 C4, C10 22u radial electrolytic, 10V (2
 off)
 C5, C7, C15, C19 to C23 100n
 ceramic disk, 5mm pitch (8 off)
 C6, C16 1u radial electrolytic, 10V (2 off)
 C8, C9, C11 10p ceramic disk,
 5mm pitch (3 off)
 C12 100p ceramic disk, 5mm pitch
 C13 1n ceramic disk, 5mm pitch
 C14 10n ceramic disk, 5mm pitch
 C17 10u radial electrolytic, 10V

Semiconductors

D1 1N4148 signal diode
 IC1 MAX660 DC-to-DC converter
 IC2 MAX038 function generator
 IC3 TL082 dual opamp
 IC4 78L05 +5V voltage regulator
 IC5 PIC16F877-4P microcontroller (pre-programmed – see text)
 IC6 74HC4040 12-stage binary ripple counter
 IC7 74HC132 quad dual-input Schmitt NAND gate
 IC8 79L05 -5V voltage regulator

Miscellaneous

S1 to S4 s.p. push-to-make switch (4 off)
 S5 to S7 s.p.d.t. miniature toggle switch (3 off)
 X1 3.2768MHz crystal
 X2 2-line 16-character (per line) LCD module (see text)

PCB available from the *EPE Online Store* (code 7000268) at www.epemag.com.
 knob (2 off); 8-pin DIL socket (2 off); 14-pin DIL socket; 16-pin DIL socket; 20-pin
 DIL socket; 40-pin DIL socket; 1mm pin header strips (see text); 1mm terminal
 pins;
 2mm socket (7 off, various colors) (or sockets to suit other equipment); plastic
 case,
 205mm x 108mm x 57mm; plastic feet for case (4 off); PCB mounting supports
 (4 off); PP3 battery and clip, or socket to suit external power supply (see text);

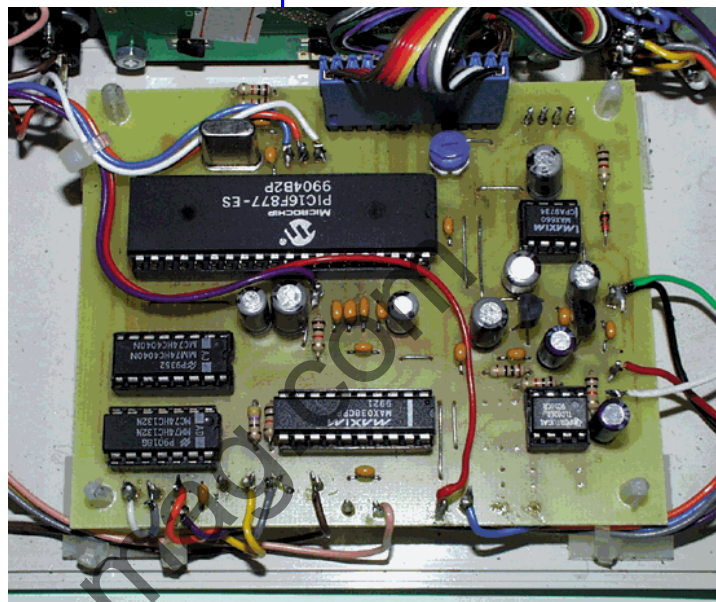

Completed prototype PCB. Differs slightly from final model.

supply is inverted to become – 9V.

The MAX660 has a much greater output load capability than the more familiar ICL7660 (and similar) devices, typically about 100mA as compared with 20mA. ONLY the MAX660 should be used in the PIC-Gen.

It had been expected that the MAX660 could have been powered by the 5V regulated supply from IC4, producing –5V as a result. However, the first test model of the PIC-Gen showed significant instability in the frequency generated when this method was used. Investigation showed that the ripple frequency output by the MAX660 could not be dampened sufficiently to prevent it from modulating the MAX038 frequency output.

Approx. Cost
Guidance Only

(Excluding case, batts)

\$90

within the PIC-Gen circuit at any other voltages (normal power supply tolerances apply).

The 5V supply is also used by the MAX038, but this device additionally requires a supply of –5V. A double-staged circuit is used for this purpose, based

around IC1 and IC8.

IC1 is a MAX660 voltage converter, used here to generate a negative voltage of the same (inverse) magnitude as the voltage at which it is powered. In this instance, the 9V

Consequently, it was found necessary to first generate $-9V$ and then to regulate and stabilize it down to $-5V$ using IC8, a negative voltage regulator. Further smoothing is given by the use of resistor R3 and capacitors C23 and C24.

A small instability remains, believed to be due to the MAX066's square wave oscillator radiating into other parts of the circuit (an oscilloscope probe on a range of 10mV just picks up the signal when held near to the device). The instability is principally noticeable at higher MAX038 frequencies.

PROGRAMMING CONNECTIONS

As is customary with the author's recent PIC projects, the PIC device used in this circuit can be programmed in-situ on the printed circuit board. The usual four connections are provided, $\sim MCLR$ (V_{pp}), DATA, CLK, and 0V, accessible via connector TB2, whose connections are in the same now-familiar order. Diode D1 and resistor R6 are part of the required control configuration. The *EPE PIC Toolkit Mk2* (May/June '99) is an ideal programmer to use.

MISCELLANY

Resistors R10 to R13 are pull-down resistors to appropriately bias the respective PIC input pins when switches S1 to S4 are not pressed. NAND gate IC7d has its inputs biased to a power line ($+5V$ in this case) as is required for unused CMOS gates. Opamp IC3b had been intended for use as an external analog input amplifier, but it was decided that the configuration around IC7c

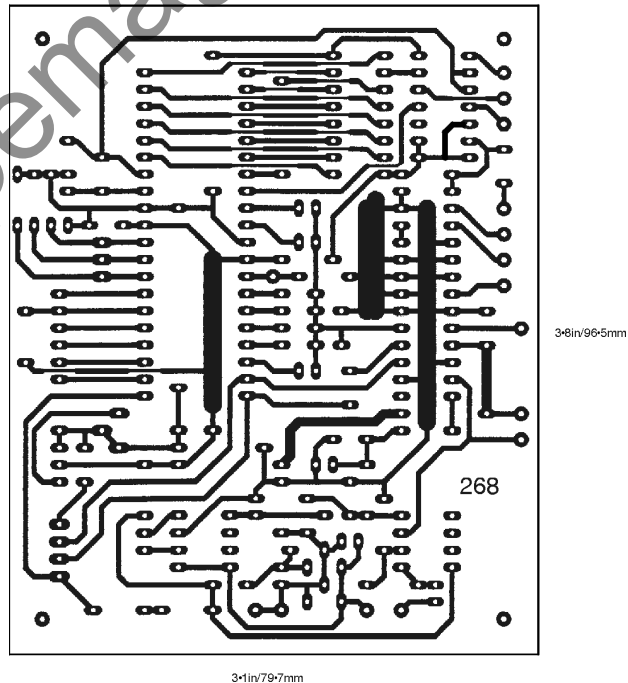
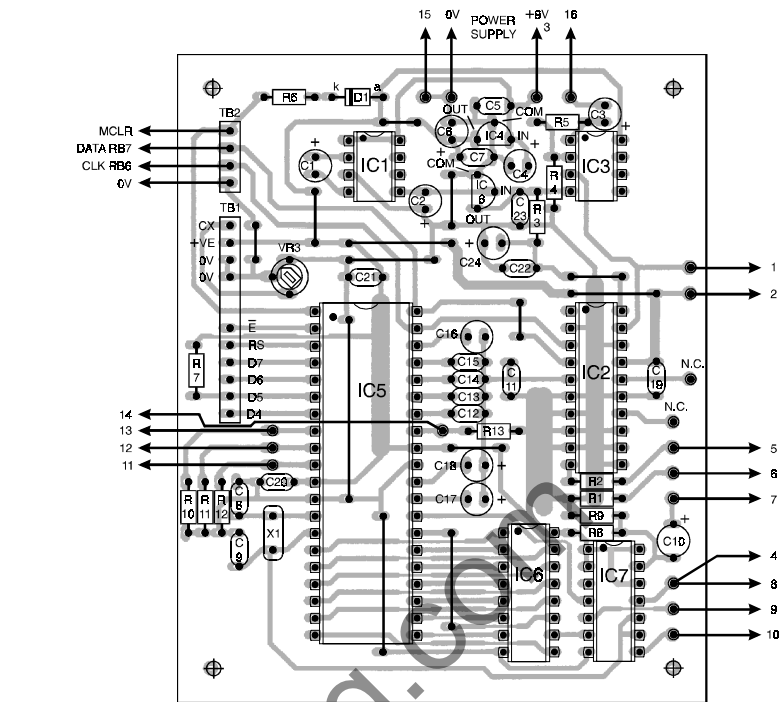

Fig.2. PIC-Gen PCB component layout and (approximately) full-size copper foil master pattern. The numbers at the ends of the lead-off wires should terminate at identical points on the front panel (Fig.3).

provided cleaner signal control, and at a far higher frequency.

If users need to frequency-

count signals having a peak-to-peak value less than about 2V, they should pre-amplify them first.

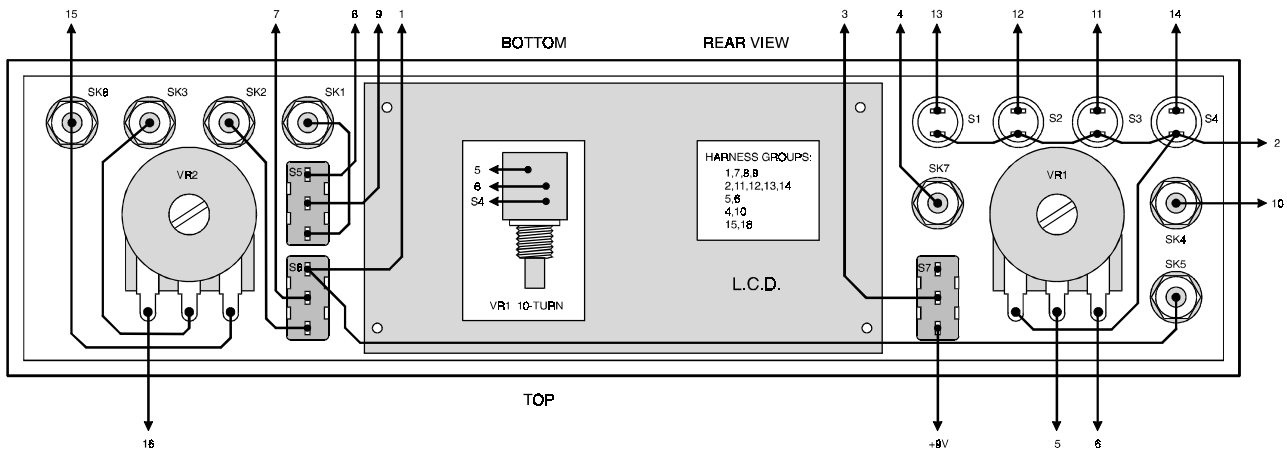

Fig.3. Layout and wiring to the front panel (full size) mounted components. The inset panels show wiring to a multiturn pot and suggested wire groupings.

Only the HC versions of IC6 and IC7 should be used (74HC4040 and 74HC132). These are typically capable of handling signals in excess of 40MHz. The “standard” CMOS 4040 counter is far too slow to be usable in this circuit. The use

of a 74LS132 should allow lesser amplitude external signals to be input to the frequency counter, typically having a peak-to-peak swing of about 0-8V, although this has not been tried.

Numerous smoothing

capacitors are used throughout the circuit at strategic points on the PCB.

CONSTRUCTION

Details of the component and track layouts for the PIC-

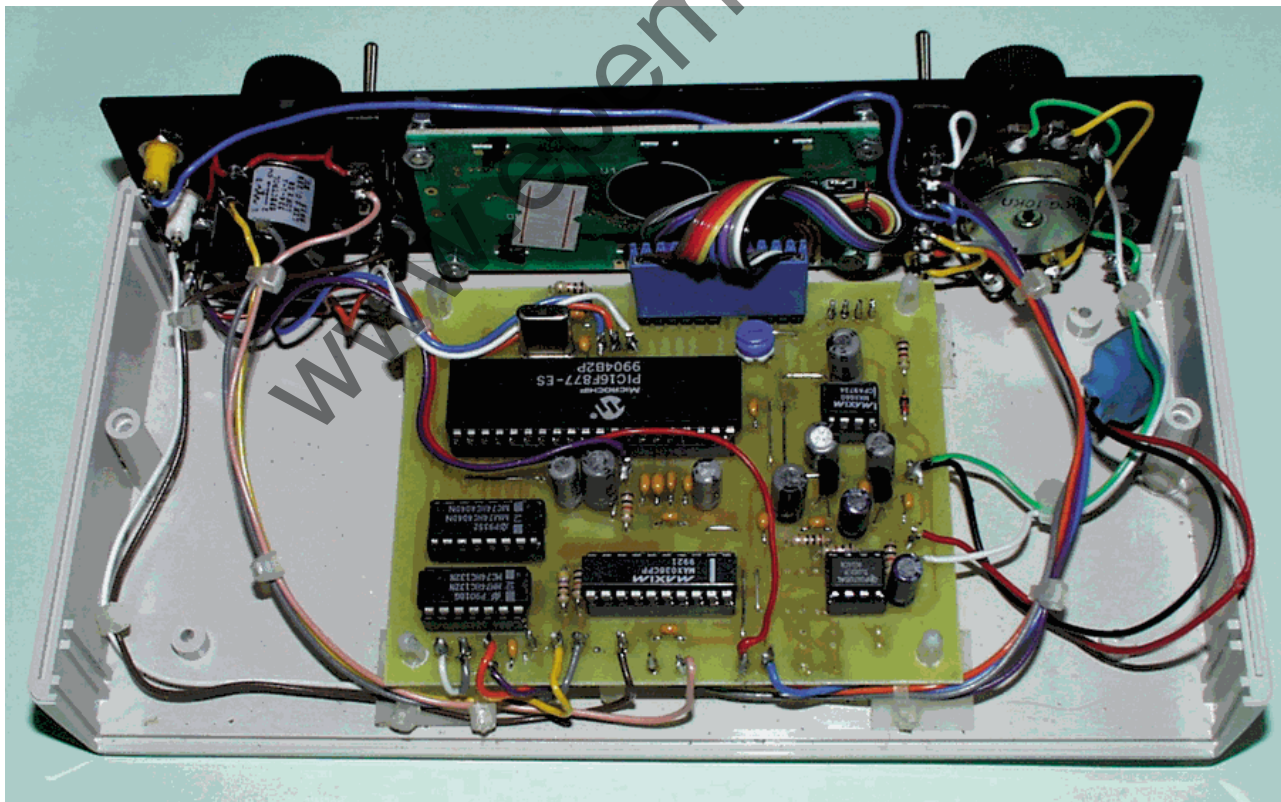

Layout of components and wiring inside the case of the completed prototype PIC-Gen. There are very minor differences between this and the final wiring diagrams. Note the various wiring “looms”.

Gen PCB are shown in Fig.2. This board is available from the *EPE Online Store* (code 7000268) at www.epemag.com

The author's preferred assembly is in order of link wires (some go under IC positions), IC sockets, resistors, diode, small capacitors, and remaining components in ascending order of size. Do not insert the DIL (dual-in-line) ICs at this stage.

Ensure that all polarized components are orientated as shown in Fig.2.

Pin-header strips were used for terminal groups TB1 and TB2. The order of these connections is identical to that used in the author's recent PIC projects. Details of the source for the LCD module complete with matching connector are given on this month's *Shoptalk* page.

The prototype PIC-Gen is housed in a plastic case measuring 205mm x 108mm x 57mm. The layout and interwiring of the off-board components on the rear of the case's front panel are shown in Fig.3. The illustration is to scale. (Note that the photographs show slightly different panel wiring to that in Fig.3.)

A choice of frequency control potentiometer is offered. The illustration in Fig.3 shows the connections for VR1 as a standard single-turn carbon rotary potentiometer. The inset shows the typical connections for a multiturn (10-turn in the prototype) wirewound potentiometer.

The standard pot is the least expensive choice but does not allow the same degree of frequency setting precision as the more-expensive multiturn pot.

To minimize the possibility

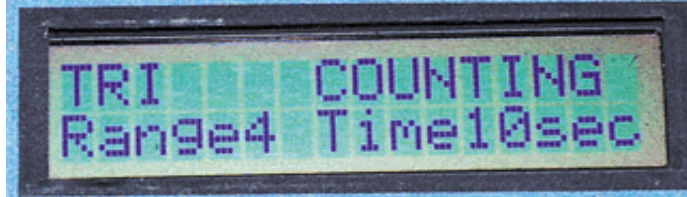

When the sampling rate change switch is pressed, the word "counting" is displayed until the first new count has been completed. In this instance a 10-second sampling rate has been selected.

Table 1: PIC16F877 configuration bits.

CP1	CP0	DBG	NIL	WRT	CPD	LVP	BOR	CP1	CP0	POR	WDT	OS1	OS0
1	1	1	1	1	1	0	0	1	1	0	0	0	1

of signals interacting with each other through the interwiring, several "harness" groups were used, keeping potentially interactive signal paths apart as seemed reasonable. The groups can be seen in the photograph, and they are itemized by connection number in the second insert of Fig.3.

Several cable ties are used to keep each group separately harnessed.

CHECK-OUT

During the checking-out of the circuit, power should always be switched off before inserting ICs or making other alterations. Switch off immediately if the circuit does not behave as expected, rechecking your assembly for errors.

Assuming that you have thoroughly checked that you have not made assembly or soldering errors, the first check should be with the LCD and all ICs omitted except the two regulators IC4 and IC8.

With power applied, check that +5V is present at the output of IC4 and at strategic points around the PCB (referring to both Fig.1 and Fig.2).

Insert the negative voltage

converter IC1 and check that a negative voltage equivalent to the applied power supply is present at its output (i.e. -9V for a +9V supply). Check that -5V is present at the output of regulator IC8 and at the pin 20 position of the socket for IC2.

If all is satisfactory, the remaining ICs and the LCD can be inserted. Only one LCD line will be active until the PIC is running. Adjust preset VR3 until the active pixels are seen as slightly darkened rectangles, or the displayed text is clearly visible if the PIC is running.

If not already programmed, the PIC can have its program downloaded to it on the PIC-Gen board from a suitable PIC programmer, connecting the programmer via pin header TB2.

The PIC configuration (initialization) required is the *PIC Toolkit Mk2* default as shown in Table 1.

Once programmed, the PIC should immediately start running and a set of data similar to that previously discussed should be seen. Set switches S5 and S6 so that the frequency being generated by IC2 is being monitored. Observe the results when different waveforms, frequency ranges and sampling rates are selected using

switches S1 to S4 and with the frequency control potentiometer VR1 at various settings.

If you have an oscilloscope, monitor the waveforms output at all settings and from all panel outputs. Additionally check the two inputs, using an external signal generator. Outputs Out Direct and AC Out should only be fed into the AC Input (do not feed them into the Logic Input because of their negative-going content).

(You may prefer to insert a 1k resistor between socket SK1

and switch S5 to minimize the risk of IC7a becoming distressed by negative-going or over-voltage signals.)

Once fully checked, the PIC-Gen is ready to be put into general workshop use.

RESOURCES

The software for the PIC-Gen is available for free download from the *EPE* Online library at www.epemag.com. The program is written in TASM.

Data sheets for the MAX038 and MAX660 can be downloaded from Maxim's web site at www.maxim-ic.com

Data sheets for the PIC16F877 (and other PIC products) can be downloaded from Microchip's web site at www.microchip.com

www.epemag.com