

**Copyright © 2008, Wimborne Publishing Ltd**  
**(Sequoia House, 398a Ringwood Road, Ferndown, Dorset BH22 9AU, UK)**  
**and TechBites Interactive Inc.,**  
**(PO Box 857, Madison, Alabama 35758, USA)**

**All rights reserved.**

**The materials and works contained within EPE Online — which are made available by Wimborne Publishing Ltd and TechBites Interactive Inc — are copyrighted.**

TechBites Interactive Inc and Wimborne Publishing Ltd have used their best efforts in preparing these materials and works. However, TechBites Interactive Inc and Wimborne Publishing Ltd make no warranties of any kind, expressed or implied, with regard to the documentation or data contained herein, and specifically disclaim, without limitation, any implied warranties of merchantability and fitness for a particular purpose.

Because of possible variances in the quality and condition of materials and workmanship used by readers, EPE Online, its publishers and agents disclaim any responsibility for the safe and proper functioning of reader-constructed projects based on or from information published in these materials and works.

In no event shall TechBites Interactive Inc or Wimborne Publishing Ltd be responsible or liable for any loss of profit or any other commercial damages, including but not limited to special, incidental, consequential, or any other damages in connection with or arising out of furnishing, performance, or use of these materials and works.

#### READERS' TECHNICAL ENQUIRIES

We are unable to offer any advice on the use, purchase, repair or modification of commercial equipment or the incorporation or modification of designs published in the magazine. We regret that we cannot provide data or answer queries on articles or projects that are more than five years' old. We are not able to answer technical queries on the phone.

#### PROJECTS AND CIRCUITS

All reasonable precautions are taken to ensure that the advice and data given to readers is reliable. We cannot, however, guarantee it and we cannot accept legal responsibility for it. A number of projects and circuits published in EPE employ voltages that can be lethal. You should not build, test, modify or renovate any item of mains-powered equipment unless you fully understand the safety aspects involved and you use an RCD adaptor.

#### COMPONENT SUPPLIES

We do not supply electronic components or kits for building the projects featured; these can be supplied by advertisers in our publication Practical Everyday Electronics. Our web site is located at [www.epemag.com](http://www.epemag.com)

**We advise readers to check that all parts are still available before commencing any project.**



To order your copy for only \$18.95 for 12 issues go to [www.epemag.com](http://www.epemag.com)

# Constructional Project

## CANUTE TIDE PREDICTOR

by JOHN BECKER

**A simple tide calculator for paddlers, dabblers, and kings of the sand castle.**

*King Canute (or Knut) (c.944-1035). Danish king who finally became King of England (after 1016) as well, taking an English wife and maintaining peace and security. A 12th-century legend describes how he rebuked his flatterers by commanding the waves to stand still – in vain of course – to show the limits of his power. The Reader's Encyclopedia.*

-----

For over ten years, the author had felt that his power over the waves was also severely limited. Not in some megalomaniac sense, you understand, but in trying to write a computer program that would allow him to predict the state of the tide for any of his favorite coastal laze-about.

Could he walk out to that rocky point without having to swim? Could he swim in that broad sweeping bay without having a kilometer walk out across sand?

All too often, and too late,

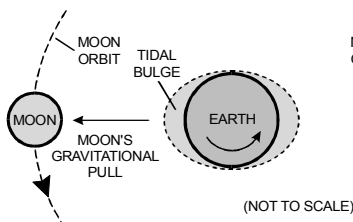

**Fig.1. The Moon's gravitational pull causes the oceans to bulge in line with it, resulting in the tide rising and falling over a period of about 12 hours 25 minutes as the Earth rotates.**

he'd found that the answers were negative! What was needed was a device or computer program that would allow the answers to be immediately displayed. Naturally, it would allow predictions to be accurate within minutes – the mechanism of tide movement was, after all, subject to strict laws of nature and thus readily calculable...

Huh! How naive!

### LUNACY

We all know (don't we?) that the Moon goes round the Earth and that its gravitational force pulls on Earth's seas and oceans such that they bulge towards the Moon on one side of the Earth's globe, and away from the Moon

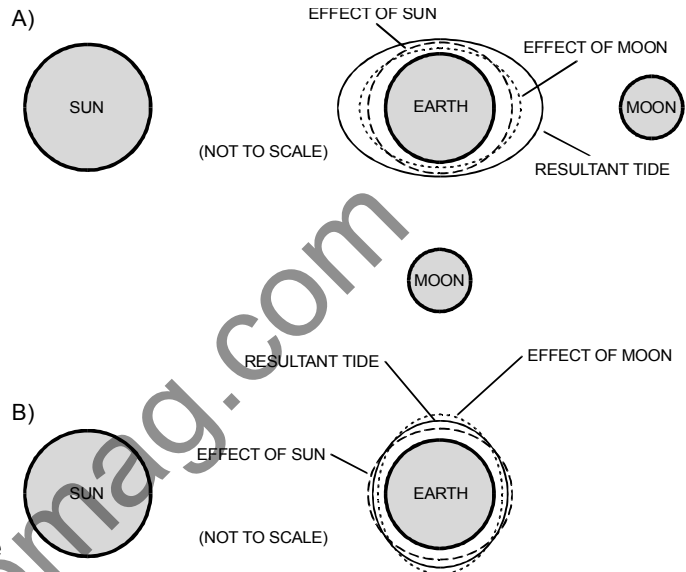

**Fig.2. The Sun and Moon both pull on the oceans, their relative angles to the Earth causing different tide heights throughout a lunar month.**

on the opposite side (Fig.1). We also know that the Earth rotates beneath the Moon, causing the relative positions of the tidal bulges to change accordingly.

Probably drilled into us from childhood is that each day's high tides are about one hour later than the previous day's. Practical experience tells us that there are two tides per day, with about twelve and half hours between them, each caused by one or other of the bulges.

Typically, the rise and fall of the tides is sinusoidal, as illustrated in Fig.1, although there are many local exceptions. Indeed, the author once designed a simple electronic tide predictor that used a tuned slow-speed sine wave generator whose output amplitude was

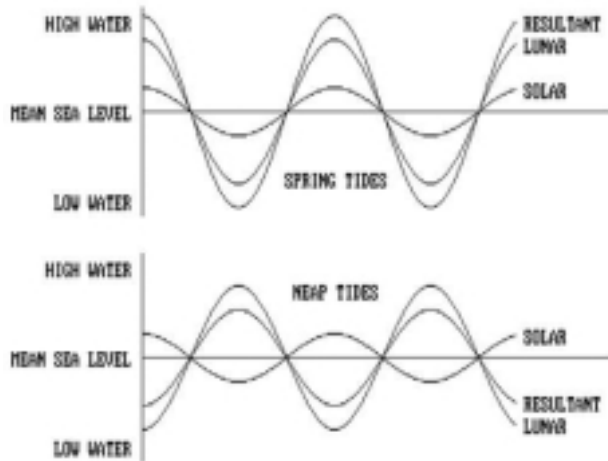

Fig.3. Spring and neap tides are caused by the relative changes of the Sun and Moon positions.

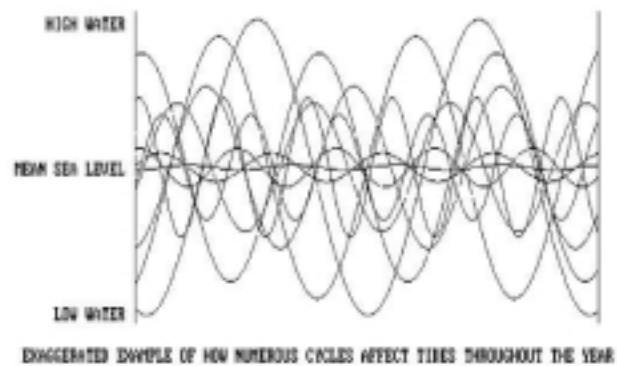

Fig.4. Many cycles other than those directly caused by the Sun and Moon affect tidal ranges. In the compilation of official tide tables, oceanographers could use as many as 115 separate components in their calculations, all having base data that has been recorded by observation over many generations.

displayed on light emitting diodes. (This was published in PE July '92, and is no longer available).

Although the device had limitations, it provided an approximate guide to tide conditions at any preset location. As recently as October '98, a reader in South Africa, Johan van Rooyen of Cape Town, told the author that he still used this tide meter and found it successful. He went on to suggest, however, that it should be updated to use a microcontroller and consume less battery power.

There are several key words in the last paragraph – limitations, approximate and preset location. It was those factors that the author had already been trying to resolve via computer.

### NOT TIDE EXACTLY

The problem is that although the average period between tides can be tied down to a value of about 12 hours and 25 minutes, there is a daily difference that varies on a cycle.

In fact, it varies according to several cycles. The principal one is caused by the Sun also having an influence on tidal movement, it too causing tidal bulges on opposite sides of the globe.

In Fig.2a are shown the tidal bulges which appear on opposite sides of the Earth when the Sun and Moon are in line with it – their gravitational pulls adding together to increase the height of the bulges. In Fig.2b is shown the situation when the Sun and Moon are at right angles to each other with respect to the Earth – their gravitational pulls tend to cancel out and so the bulges are less pronounced.

This is why relative tide height ranges change throughout a lunar month, spring (very high) tides when the Sun and Moon are in line with the Earth, neap (very low) tides when they are at 90 degrees (right angles) to each other, see Fig.3. Springs occur just after every full and new moon, typically between 36 and 48 hours later. Neaps occur when

the Moon is in the first or third quarter.

The height of spring tides varies with the seasons. Those nearest the equinoxes (21 March and 21 September), when day and night have equal length, are somewhat higher.

Because it takes longer for a volume of water to sweep up and down over a wide tidal high-low range than over a narrow range, so the period between the tides changes according to the Sun and Moon positions. Here, then, is the cause of the first deviation from the nominal 12 hours 25 minutes tidal period.

### TERRAINOSAURUS

Another factor is the terrain over and through which the tidal mass has to travel. This has the effect of slowing or increasing the rate at which the tidal current flows back and forth.

Many other factors also affect the rate of tidal change. For example, river estuaries heavily influence the rate at which the tide can rise and fall, not only because

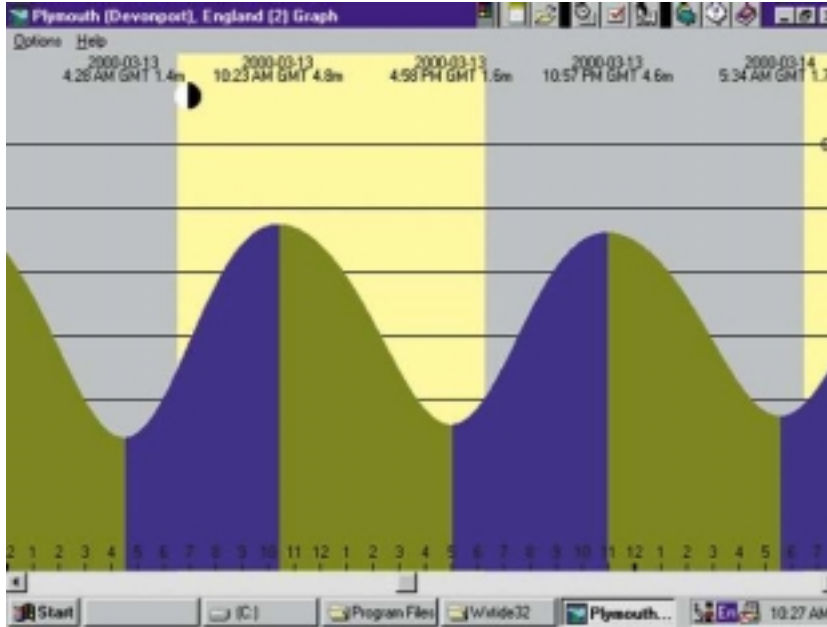

Fig.5. Screen dump of the tidal predictions made by web-based WXTIDE for Plymouth, UK, 13 March '00. Note the half-moon symbol.

## OFFICIAL TIDE TABLES

In the UK, the Proudman Oceanographic Laboratories (POL) compute the official tide tables that are quoted in newspapers and other publications.

POL, in their web-based educational demo, state that their predictions can use up to 115 components, each with different frequencies, amplitudes and phases. A screen-dump of a simulation using only a few of the possible components is shown in Fig.4.

Rapidly, therefore, have we moved beyond the simple twelve and half hours tidal period referred to earlier.

Whilst the 115 or so variables can be calculated mathematically, you first need the data which defines them. And here's the rub – the data has been compiled over many generations through direct observation at specific locations, and the data can change as coastal erosion occurs. It is from the observational data that individual cyclic factors are extrapolated.

Some of the data is in the public domain (we shall quote a particularly good web-download source later, a screen dump of one of its prediction graphs is shown in Fig.5). Other data is copyright and needs to be purchased.

## WITH THE FLOW

So, realistically, how many variables can be used by a computer program for predicting tides? The answer, in terms of hobbyist software writers, is very few.

Three were used in the author's early experimental PC

of the funneling effect, but also due to the volume of fresh water that rivers carry. An unpredictable factor also becomes apparent when seas and oceans suffer heavy storms, the high winds and abnormal atmospheric pressure causing the water mass to be shifted, resulting in higher tides on the receiving shores.

Nor does the Moon remain at a constant distance from the

Earth, which in turn affects its gravitational pull on the tides. The moon's orbit is actually an ellipse, its distance varying from 221,460 miles (perigee) to 252,700 miles (apogee).

A similar factor relates to the Earth's orbit around the Sun, varying from 91,400,000 miles to 94,600,00 miles, with a mean distance of 92,957,209 miles.



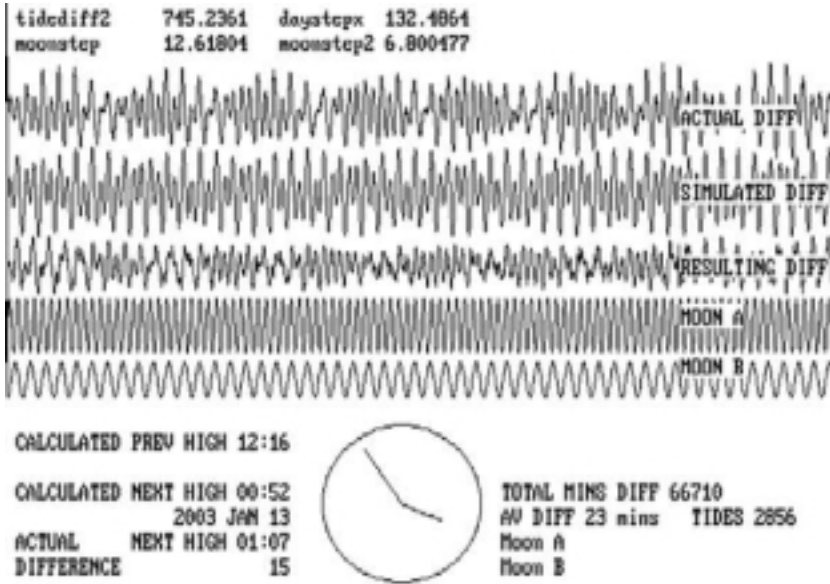

Fig.6. Screen dump of the author's computer-based tide prediction simulation over a 5-year period. The waveforms are explained in the text. It was from this simulation that the Canute Tide Predictor software for a PIC microcontroller was developed.

software, daily Sun and Moon positions on fixed cycles, and a seasonal adjustment for the sun's angle to the equator, also on a fixed cycle.

The simulated tidal predictions were accurate to within about 25 minutes when compared against published official tide tables, which he had acquired over several years.

At the time, the author was unaware that tides were professionally predicted from observed data cycles rather than purely trigonometric values (sine waves, concentric circles, ellipses, parallelograms of forces, etc.).

No matter how hard he coaxed "ze little grey cells" and modified software, greater accuracy seemed unattainable. He didn't know why, and had been hoping to be within about five minutes of official predictions.

After several attempts over

the years, he eventually gave up. Until that is, the South African reader offered his encouraging comments. Discussions with Editor Mike, who is a keen sailor, resulted in us concluding that such accuracy was irrelevant to most

people. Even he initially only needed to know roughly the time of high or low water in Poole Harbour! Others might only need to know whether to go to the beach in the morning or the afternoon.

Consequently, it was decided that a simple microcontrolled unit with liquid crystal display and an accuracy somewhat less than that originally envisaged would suffice.

### MICRO LIMITS

However, whilst the computer program was able to achieve accuracy to within about 25 minutes, the limitations of a small microcontroller prevent a similar accuracy being achieved by an inexpensive small handheld unit. Whereas a PC can store data in many files on disk or in its memory, a microcontroller has limited memory and data storage capacity.

Its processing speed also places a severe limit on how many variables it can process

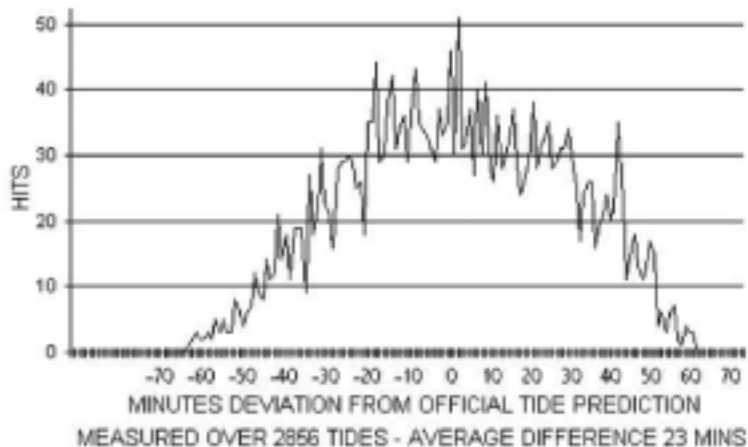

Fig.7. Screen dump of the tide prediction accuracy as calculated by the program referred to in Fig.6 and displayed using Microsoft Excel.

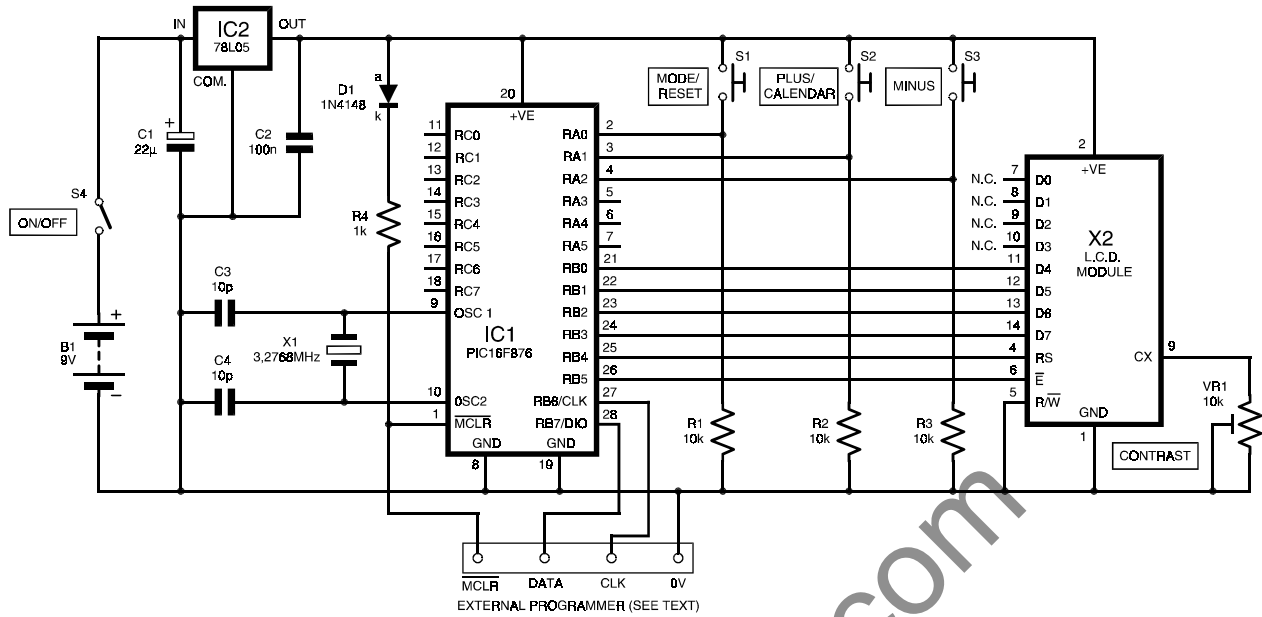

Fig.8. Complete circuit diagram for the Canute Tide Predictor.

while still maintaining accurate time and calendar data, even if the variables were to be held in external memory. The lack of multiplication and division commands on a typical microcontroller also impose processing speed problems.

It was decided, therefore, that only the two main variables, relative Sun and Moon positions, would be used in the basic calculations. In comparison with published tide tables for Plymouth (downloaded from the web), the accuracy of the

author's prototype, as described here, remained within about one hour over a simulated five year period, with an average deviation of about 23 minutes, but with many predictions being much closer. A screen dump of the simulation is given in Fig.6.

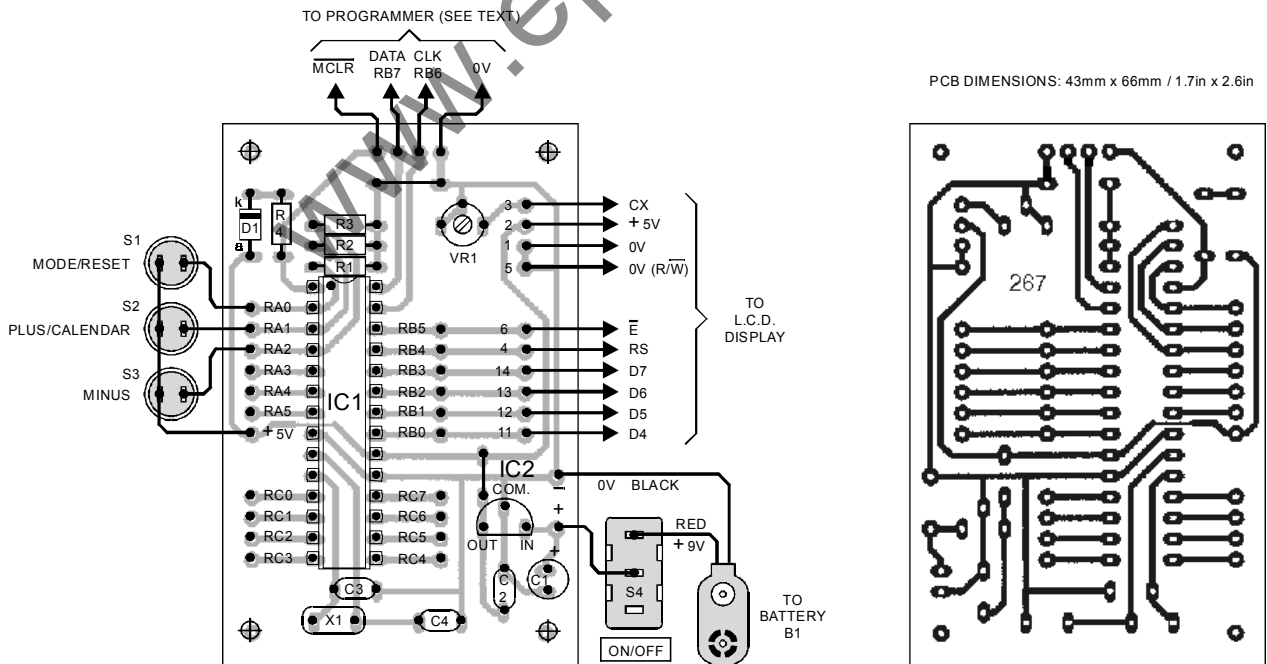

Fig.9. Printed circuit board component layout, wiring to off-board components and (approximately) full-size copper foil track master pattern for the Canute Tide Predictor.

Moon B waveform is the representation of the standard lunar cycle, Moon A represents the spring and neap tide cycle as caused by the relative angles of the Sun and Moon.

Although it may not be apparent from Fig.6, the Moon A and Moon B waveforms are sinusoidal, Moon A running at a cycle rate of just under twice that of Moon B (a ratio of 12.61804 to 6.800477) the amplitudes of the two waveforms are also precisely related, as are their initial phases.

The Actual Diff waveform is drawn from the downloaded tide values being pulled in from disk. The Difference being that between the basic 745.2361 minutes between tides, and that which actually exists. The Simulated Diff waveform is the sum of Moon A and Moon B, which is compared with the Actual Diff to produce the Resulting Diff. Had the Actual and Simulated Diffs been exactly matched, the Resulting Diff would be shown as a straight line.

Five years of tides (2856) are represented. A cumulative total of the Resulting Diff shows a value of 66710 which is divided by the tide count to produce an average difference of 23 minutes.

The "clock" is an animation illustrating the angles of Moon A and Moon B at any moment during the simulation.

The graph in Fig.7 illustrates a summary of this simulation. Horizontally, the graph shows the minutes deviation from the downloaded prediction. Vertically, the number of "hits" on the minutes of deviation are recorded.

## CIRCUIT DIAGRAM

The *Canute Tide Predictor* is based on software embedded into a PIC16F876 microcontroller. This device, as discussed in previous *EPE* articles, has 8192 bytes of program memory available, 368 bytes of data RAM and 256 bytes of EEPROM data storage. The software will be discussed later.

First, let's quickly describe the *Canute Tide Predictor* circuit diagram, as shown in Fig.8, and the unit's construction.

The PIC microcontroller, IC1, is operated at 3.2768MHz as set by crystal X1. There are three pushbutton switches, S1 to S3, which control several functions, as discussed when the software is described. The switches are connected to Port A pins RA0 to RA2, which are normally biased low via resistors R1 to R3.

Data is output to the liquid crystal display (LCD), X2, which functions in conventional 4-bit mode. Its screen contrast is adjustable by preset VR1.

The option to program the PIC yourself is made available via the ~MCLR, Data (RB7), Clock (RB6) and 0V connections. Diode D1 and resistor R4 allow a 12V to 14V programming voltage (Vpp) to be fed to the ~MCLR pin, with the rest of the circuit being unaffected. This is in keeping with other *EPE* PIC projects, which can be programmed using PIC Toolkit Mk2 (May-June '99).

The pin order and spacing of the LCD and programming connections on the printed circuit board (PCB) are the same as that used by the author on his other recent PIC constructional projects.

Power to the design can be

from a PP3 9V battery (B1), with regulator IC2 dropping the voltage to 5V, as required by the PIC and the LCD. Component S4 is the power on/off switch. Current consumption is just under 6mA.

Power may alternatively be supplied by a mains operated 9V battery eliminator (adapter) via a suitable socket.

It will be apparent that this circuit can be used as the base for a wide variety of other PIC16F876 (and '873) controlled applications, for which other software can be written. The PCB has been designed with this in mind, with access connections available to make use of Port C and the unused pins of Port A.

It may also be of interest to know that although the author used a PIC16F876, this was because he had them in stock. The PIC16F873 may be used instead. Furthermore, the software can also be run on the PIC16F874 and '877 without modification, provided that the PCB is redesigned to accept these larger devices. (Much of the original prototype software evaluation was done with an existing board designed for the '877.)

The software is not suitable for running on other PIC devices. It is too lengthy and has too many variables to be run on the PIC16x84, for example. The program is around 2000 commands long.

## CONSTRUCTION

Details of the PCB component and track layouts are shown in Fig.9. This board is available from the *EPE Online Store* (code 7000267) at [www.epemag.com](http://www.epemag.com)

Use a socket for IC1 and

## COMPONENTS

### Resistors

R1 to R3 10k (3 off)  
R4 1k  
All 0.25W 5% carbon film or better

### Potentiometer

VR1 10k miniature round preset

### Capacitors

C1 22u radial electrolytic, 16V  
C2 100n ceramic disc, 5mm spacing  
C3, C4 10p ceramic disc, 5mm spacing (2 off)

### Semiconductors

D1 1N4148 signal diode  
IC1 PIC16F876 pre-programmed microcontroller (see text)  
IC2 78L05 +5V 100mA voltage regulator

### Miscellaneous

S1 to S3 miniature push-to-make switch (3 off)  
S4 miniature s.p.s.t. or s.p.d.t. toggle switch (see text)  
X1 3.2768MHz crystal  
X2 16-character, 2-line alphanumeric liquid crystal display

Printed circuit board available from the *EPE Online Store*, code 7000267 ([www.epemag.com](http://www.epemag.com)); 18-pin DIL socket; terminal pins; case 150mm x 80mm x 50mm; 9V PP3 battery and clip (see text); connecting wire, solder, etc.

See also the  
SHOP TALK Page!

Approx. Cost  
Guidance Only

\$38

assemble the components in any order you feel comfortable with. Ensure the correct orientation for IC1, IC2, D1 and C1. Off-board connections are also shown in Fig.9. The use of 1mm terminal pins is recommended for these.

The LCD may be supplied in one of two pin configurations, as given in Fig.10. The top configuration in Fig.10 is the one used by the author. This device was supplied with a ready-fitted connector which matches the

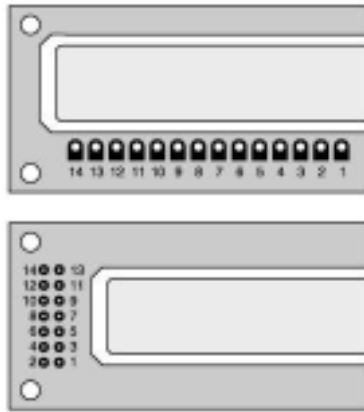

Fig.10. Pinout arrangement of the two basic LCD formats.

pin order on the PCB (see [Shoptalk](#)).

The plastic case used for the prototype is larger than actually needed and a smaller one of suitable dimensions could be used instead. The cut-out for the LCD can be made by drilling holes within the perimeter of the screen area, cutting or sawing between them, and then smoothing with a file. (Why on earth doesn't any manufacturer make plastic cases with the correct sizes of cut-out for standard alphanumeric LCDs – anyone know an answer?)

## PROGRAMMING THE PIC

Details for obtaining the software (which is available for free download from the *EPE Online Library*), and preprogrammed PICs, are given in [Shoptalk](#).

The initializing configuration required by those programming their own PICs is the *PIC Toolkit Mk2* default of Table 1:

Note that in common with a few other readers, the author has encountered what seems to be a bug in the PIC16F876.

Under some programming circumstances (and they have not yet been established), the PIC can have one or more of its Code Protect flags undesirably set. It does not happen on every occasion.

The problem has been experienced by readers using several different types of PIC programmer. On the *PIC Toolkit Mk2* programmer the problem is revealed when the verification process (if active) states that masses of errors have been encountered.

The author found that, despite this message, the PIC had been correctly programmed. Consequently, unless you know that you have made a mistake (as listed on the error-reporting screen), you can probably assume that your device is correctly programmed. The truth of the matter will become apparent when you run the PIC in circuit.

Feedback is requested from readers who have experienced this code-protection problem, and brief details of the conditions under which it occurred.

## PROGRAM OPERATION

Before first powering up the Tide Predictor, press Mode/Reset switch S1 and keep it pressed while you switch on the power, S4. Assuming that you have made no assembly errors, you should see the screen activated for two lines of data stating:

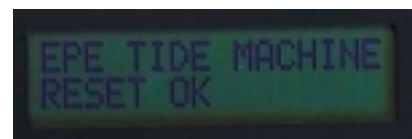



**Table 1**

CP1	CP0	DBG	NIL	WRT	CPD	LVP	BOR	CP1	CP1	POR	WDT	OS1	OS2
1	1	1	1	1	1	0	0	1	1	0	0	0	1

Adjust preset VR1 until a reasonable image contrast is seen.

At switch-on, with Mode/Reset S1 pressed, the program resets all data to default values as written into the code. The data is copied into some parts of the EEPROM memory and some into the working variable registers.

**LOOK-UP TABLES**

Look-up tables for month and weekday names (abbreviated) are copied into EEPROM at known addresses, easing and speeding their future access. The time and calendar data for the instant that the year 2000 commenced is also stored.

Also stored in EEPROM are the values of the two variables used in the simulation of the Sun and Moon positions. These relate to tidal conditions at an imaginary location (but probably not far from Plymouth, Devon, UK) at that moment in time.

They have been calculated as preset values such that without further time correction a high tide occurring at 00:59 would be predicted. It is from these base values that all future tide predictions are calculated, irrespective of location and local time.



Release Mode/Reset S1. The screen will now display:

Note the flashing asterisk under the year 00. Using either push switch S2 or S3, the year

value can be incremented or decremented. Press S1 to move the asterisk below the A of JAN, and the SET YOUR DATE message disappears. The month value can now be changed using S2 or S3.

The process is repeated for each of the other date and time factors. Once the hour value has been set and S1 pressed again, the tide prediction calculation is performed and the lower LCD line will be similar to:

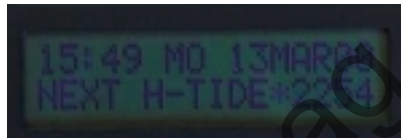

where the asterisk is again flashing and the time of the next high tide will be seen for the date you have set for the imaginary location referred to above.

You now need to refer to published tide tables in order to find out the actual high tide predicted officially for that date and following the basic clock time you have set. More details on finding such facts are given later.

The program allows the tide time to be increased or decreased in steps of six minutes, again using S2 or S3. The time is according to a 24-hour clock and rolls over appropriately depending on whether the value is being increased or decreased. Set the time for your next high tide.

Press S1 (Mode/Reset) again to change the lower line to read:

**FAST/SLOW \*+0000**

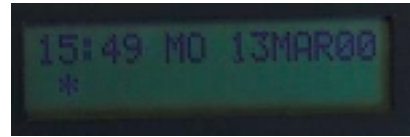

This allows the real-time clock to be corrected to run faster or slower should the PIC's system clock not be running spot-on. You may not know for a few days whether or not it needs adjusting. Leave the value at zero for now.

Again press S1, causing the lower line to display the ALL DONE message:

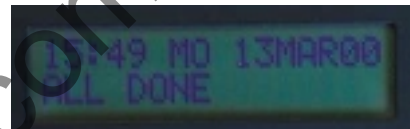

Between you pressing S1 and this message appearing, the new data is stored in EEPROM and will stay there until you change it again, even when the Tide Predictor is switched off.

**TIDAL BARGRAPH**

With the ALL DONE message now displayed, pressing S1 again puts the Tide Predictor into its normal running mode.

On the top line is shown a bargraph, the darkened pixels indicating the current state of the tide. At the right of the top line will be seen either a ">" symbol, indicating that the tide is rising, or a "<" symbol indicating a falling tide.

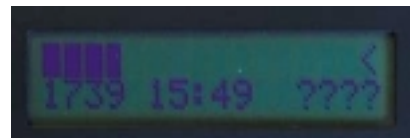

The terms rising and falling should be treated loosely. What they mean here is that the predicted time is either still being approached, or that it has been passed. In reality, of course, the

changeover between a tide rising and it falling is not instantaneous. There is a period known as slack water when it is doing neither of these things, and no tidal currents are flowing at that location.

The slack period varies according to location and the season, but a period of half an hour is not uncommon.

Each LCD character cell (of which there are 16 per line) represents 30 minutes. Each cell has five columns of pixels, each column representing six minutes. After each group of six minutes, the display changes to show the appropriate number of darkened columns, increasing or decreasing according to the tide direction.

There is no fixed column number that indicates high or low water. As soon as the high or low water prediction time has been reached, the graph reverses direction at that point. In time you will recognize that this can give an indication of the height of tide extremes (in a relative sense, since actual tide height prediction in meters or feet is not possible without access to the data from which official sources calculate their tides).

Practical limits had to be set in the program to prevent extreme groupings of tide movements from trying to overshoot either end of the LCD. The graph will not exceed cell 15, nor go lower than column one of cell one. For the most part, the graph movement will be confined to well within these extremes.

### NUMERIC DATA DISPLAY

In line two of the display are three numeric values. The

center value shows the current time, the colon flashing at a one second rate.



At the right is shown the time of high tide. When the tide is rising (> symbol), the time is that of the next predicted tide. When the tide is falling (< symbol), it is the time of the high tide that has passed. It only changes its value when the tide has fallen to its predicted low and starts to rise again.

On the left of line two, the value is the time of low tide, either that being approached (< symbol) or the one that has passed (> symbol). The value only changes when the predicted high tide time has been reached.

Note that when the Tide Predictor is first switched on and the tide is calculated to be rising, only the time of the next predicted high tide is shown, with four question marks (????) being shown in the low tide time position.

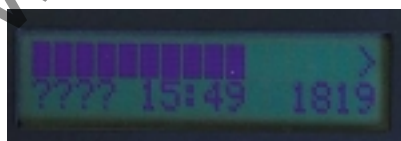

Conversely, if the tide is falling, the four question marks will be in the high tide position, but with the next low tide time being shown in its own position. The next high tide will be shown after the low tide time has been reached.

Otherwise, the low tide value is only calculated and shown when the high tide turns and begins to fall.

### CALENDAR DISPLAY

At any time during normal

running, switch S2 (Plus/Calendar) can be pressed. The display then shows time and calendar data on its lower line. The upper line continues to show the tidal bargraph.

Pressing S2 again returns line two to the prediction times display.

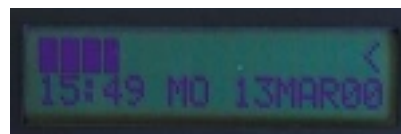

### ADJUSTING DATA

All timing factors may be adjusted during running. To enter adjustment mode, press Mode/Reset switch S1. The screen will then display the same set of changeable data as described earlier.

Any of the factors may be changed as before, simply pressing S1 to move between them. Again when all values have been changed as required, high tide prediction is calculated and all the data restored in EEPROM.

All calculations are made from the original reset default values (00:00 01JAN00) and you may "turn back the clock" if you need to.

### POWER OFF

You may not wish to keep the Tide Predictor permanently switched on, and to avoid you having to fully reset all the calendar facts from 00JAN00, the data held in the EEPROM is updated at each high tide rollover.

This means that should you switch off and restart again at a later date, you only need to update from the last set of data stored before switch-off.

## PIC CLOCK

The PIC's internal clock is set so that a clock updating routine is accessed at nominally once per second. However, the controlling crystal does not necessarily oscillate exactly at its stated rate of 3.2768MHz but is subject to a manufacturing tolerance. To compensate for this, the fast/slow adjustment referred to earlier has been included.

Thus it is not exactly one second which is added to the clock each time the routine is accessed, but a value that can be set fractionally greater or smaller than this.

A 3-byte hexadecimal value is repeatedly added to an intermediate 3-byte counter, each time the counter rolls over to zero, so the seconds counter is incremented. As expected, the minutes counter is incremented every 60 seconds! The rest of the time and calendar data is updated as appropriate, including allowance for leap years.

When adjusting the fast/slow factor, each unit of change shown on screen represents one second change per 4,194,304 seconds. There are approximately one million seconds in 11.5 days, so the potential for clock-setting accuracy is good. (By using a 4-byte counter, the ratio could have been programmed so that each unit of adjustment represented one second per 2,147,843,648 seconds!)

## CALCULATIONS

As stated earlier, tide predictions are made according to the relative angles of the Sun, Moon and Earth. On their own, these cycles do not take into account local time. For this data

## PANEL 1 – WHERE DOES IT GO?

It was when considering tidal constants for different locations that the author recognized an unexpected significance about them. Because the Earth is rotating beneath the Moon and sun, it would seem reasonable to assume that the respective tidal bulges must remain at the same relative angle to them.

Thus, at the equator, the tidal bulge should travel a little over 1000 miles per hour (the circumference of the Earth being approximately 25,000 miles). At the latitude of Land's End (about 50°N) from the equator, a rate of about 330 MPH might be expected. From this, high tide at Dover should be a little under one hour earlier than at Land's End (about 350 miles west of Dover).

The reality is vastly different, as examination of tidal constants shows (and experience confirms – when did you last see a 330 MPH tidal wave travelling up the English Channel?). In fact, the difference between high tide at Dover and Penzance (not far from Land's End) is about six hours.

So what causes a slower tidal front than logic would suggest, and what happens to the water that should be tracking the gravitational pull of our celestial neighbors? The author does not know. Answers addressed to *Readout* please!

a third angular value is used, representing the 24-hour clock cycle, which can be set to suit any time zone.

The angular positions are simulated by using three hexadecimal counters to which fixed values, having several decimal places of accuracy (in hexadecimal notation), are periodically added. Tidal predictions are made according to the relative angle counts. The process is simple in principle, but complex in terms of the program commands required. It is beyond the scope of this article to describe how the results are achieved.

It is relevant, though, to quote the values that are used as the basis for the simulation:

The average difference between tides has been calculated according to the period of the Lunar Synodic Month (LSM), given in the Astronomic Constants Index (more details later) as 29.5305888844 days. From this, the average period between

successive tides has been calculated as 745.2361 minutes, which equals 12 hours 25.23606 minutes – a value not too far off from the approximate value quoted earlier.

From the same source, the value for Earth Rotations per Lunar Orbit has been taken as 27.39646289 days. It is a subdivision of this period that is used to "modulate" the value of the LSM cycle to simulate the differing angles between Moon, Sun and Earth when prediction calculations are made.

The 24-hour clock angle, by fortuitous convention, rotates in a period of 24 hours!

These three values are subdivided within the program such that the three circular motions have their angles appropriately increased on each occasion that the LCD clock value matches that of the predicted high tide time.

From the resulting angular relationships, the times of the next high and low tides are

calculated. The next low tide time is immediately shown and the tide rising symbol changes to tide falling.

No change is made, though, to the high tide time already displayed. This now represents the time of the last high tide. For the moment, the newly calculated high tide value is simply stored.

About six (or so) hours later, when the LCD clock value matches that of the low tide prediction, the stored high tide value is displayed, along with the tide rising symbol. The existing low tide value still on display is now regarded as the time of the previous low tide.

Between the instants of tide recalculation, the bargraph display is repeatedly updated to give a visual indication of the current tide state.

### USING THE TIDE PREDICTOR

Earlier we described how the various time and date values could be changed. There is little more to using the Tide Predictor than that. In whatever part of the world that you live, providing that you can initially find out the high tide time for your preferred coastal location when first setting up the data, you can use this handy predictor.

Originally, it had been hoped to include the option to have the "tidal constants" for several locations to be programmed in and selectable. Sorry, but the author has decided the additional programming involved would keep him indoors away from the sea this summer. Perhaps one day...

However, there is a simple solution you can use. Set up the Tide Predictor for your favorite location, and from the same

source that you obtained its tide time data, also note the tide times for other locations on the same day.

Now work out and write down the time difference between your primary location and the others, to the nearest half hour perhaps. All you need do then is use a bit of simple mental arithmetic to predict tides for other locations from the primary value displayed on screen.

Should you ever feel the need to start the predictions again from zero, press switch S1 while switching on power using S4 (as described earlier).

### PROUDMAN OCEANOGRAPHIC LABORATORY

The Proudman Oceanic Laboratory (POL) is the UK's official tide prediction

organization. Their Bidston Observatory is a recognized climatological station, reporting to the UK's Met Office at Bracknell.

POL has an excellent web site at [www.pol.ac.uk](http://www.pol.ac.uk) and there are tutorial demos available for free download that illustrate the causes of tides and changes in the weather. A demo version of the POLTIPS tidal prediction software can be downloaded as well (the full version may be purchased). The site has links to other global tide prediction agencies.

A 58-page brochure detailing other facilities offered by POL can also be downloaded.

Records going back to 1845 are held by POL. For 125 years the readings were obtained by manual observation. Today they have an automatic weather logger that takes readings every three seconds.

### PANEL 2 – VITAL NOTE!

The *Canute Tide Predictor* has probably been one of the most challenging software controlled designs the author has ever produced (being preceded by a decade of programmed experiment!). The code routines have been difficult to write, but they seem to produce realistic values when compared against published tide tables.

However, the accuracy of the predictions cannot be guaranteed, even within the range stated earlier. There may be some combinations of angular values that the software does not handle correctly. Should you discover any, please tell the author the exact date, time and correction values when the error occurred, together with the original factors last programmed in via the switches.

**DO NOT RELY ON THIS DESIGN'S TIDE PREDICTIONS FOR ANY SITUATION WHICH MIGHT ENDANGER LIFE.** If you really need to know exact tide times, always ask the local Coast Guard and advise him of where you are going and when you expect to be back.

In his scuba-diving days, the author and fellow B.S.A.C. members used to be on CB-radio standby with our inflatables for the Coast Guard and R.N.L.I. in case of an in-shore waters emergency near our diving location. We responded on several occasions and know how important it is that people should be aware of tide and weather conditions when putting to sea in small boats or walking along shores where rising tides can cut off retreat.

There are occasional Open Days for which you can obtain free entrance tickets. This year (2000) the dates (as downloaded 10 March) are 4 June, 29 June, 7 July. Apply to Open Day Tickets, Proudman Oceanographic Laboratory, Bidston Observatory, Bidston Hill, Bidston, Prenton CH43 7RA, UK.

**Tel:** +44 (0) 151-653-8633

**Fax:** +44 (0) 151-653-6269

### WXTIDE

A really superb and highly interesting web site is that which can be accessed at [www.geocities.com/SiliconValley/Horizon/1195/wxtide32.html](http://www.geocities.com/SiliconValley/Horizon/1195/wxtide32.html) (pointed out to the author by South African reader Johan van Rooyan). From this site tide prediction software (WXTIDE32), which probably has data for thousands of locations world-wide, is available for free download. The latest version 2.6 is 1.38Mb. An earlier version was heavily used in the final stages of designing and verifying this Tide Predictor.

The global locations offered, and preferences for the way in which data can be displayed, are available via drop-down menus. Some typical screen dumps are shown in Fig.5 and Fig.11.

Gratitude is expressed to Dave Flater, whose site it appears to be, and to all those who contribute to the site, which is well presented and maintained. There are also many links to other tide-related sites (plus some covering tornadoes, of which there are amazing photos that can be pulled in).

## PANEL 3 – TIDAL HISTORY

The first tide predicting machine was invented by Lord Kelvin in 1872. He knew that tidal patterns could be modeled using sine waves, and that a sine wave can be represented by the motion of a wheel that has its shaft off-center (eccentric).

Kelvin used several different eccentric wheels, linked by a single wire around each of them along the machine. The combined effects of the up and down motion of the wheels resulted in a single up and down movement at one end of the wire to which a pen was attached, this movement simulating and illustrating tidal behavior.

Arthur Thomas Doodson (1890-1968) used this principle to help calculate the exact tides for the D-Day landings in 1944, having constructed a 42-variant version. It took this machine a day and a half to calculate the tides for one location for a year. Until computers took over, this machine remained the best in the world for tide prediction.

Doodson originally started work in Liverpool on tide prediction in 1919, ultimately making it his life's work. He and a certain Mr Proudman (of whom no more details are known) was instrumental in starting the Tide Institute at Birkenhead (now POL, named after Mr Proudman). Interestingly, a source name quoted on one POL document in 1999 is Valerie Doodson, presumably his descendent.

## ASTRONOMICAL CONSTANTS

The Astronomical Constants Index was downloaded via [www.geocities.com/Athens/Olympus/4844](http://www.geocities.com/Athens/Olympus/4844). There are other related (and unrelated)

downloads offered, including some fascinating material on archeogeodesy ("that area of study encompassing prehistoric and ancient place determination..."), and astronomy in general.

James Q. Jacobs runs this

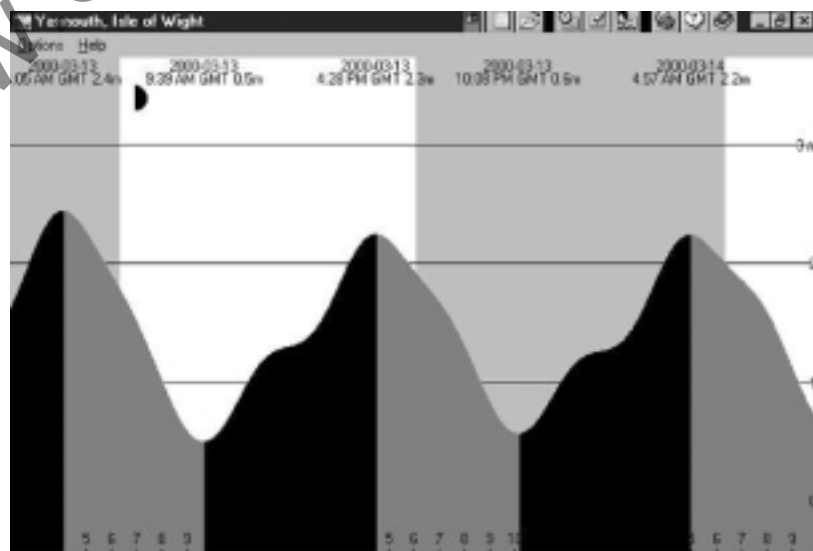

Fig.11. not all tidal movements seem sinusoidal. This screen dump shows a double-humped pattern for Yarmouth, Isle of Wight. The Canute Tide Predictor does not attempt to match such waveforms.

### TIDE LINES

330 BC. Greek explorer Pytheas, on reaching the Baltic Sea, observes strong tides and theorizes that they are caused by the Moon.

1609 AD. First attempt is made to harness tides in the Bay of Fundy as a source of power for small mills.

site and it's well worth browsing in depth. He tells us, for example, that in a translation of the work Aryabhata of Aryabhata, An Ancient Indian Work on Mathematics and Astronomy the following is written:

*"In a yuga the revolutions of the Sun are 4,320,000, of the Moon 57,753,336, of the Earth eastward 1,582,237,500, of Saturn 146,564, of Jupiter 364,224, of Mars 2,296,824, of Mercury and Venus the same as those of the Sun."*

James believes that these are oldest exact astronomic constants known. He has calculated that Aryabhata's ratio would have been exact in 1604.4 BC, at which time there were 366.2563565652 Earth rotations per solar orbit. Astonishing accuracy! Especially so when you consider that the astronomic constant for 1 Jan 2000 was recently calculated by sophisticated modern equipment to be 366.25636031 rotations. The Earth's orbit (one year) is currently 365.25636053 days. It is not known how the concept of a "yuga" was perceived.

### OTHER SITES

The BBC web site at [www.bbc.co.uk/education](http://www.bbc.co.uk/education) has links through which you can discover many things about science and technology, and gain access to related sites.

The UK Meteorological

Office site is at [www.meto.gov.uk](http://www.meto.gov.uk)

The equivalent US site (National Oceanic and Atmospheric Administration) is at [www.noaa.gov](http://www.noaa.gov)

### OTHER SOURCES

Other sources of tidal information are:

- o) Old Moore's Almanac (a worthy source for such down-to-earth information), is often available from newsagents. It quotes high water data for London Bridge, plus corrective tidal constants for a few other UK locations. It also quotes dates and times for the moon's phases, and for sunrise and sunset.
- o) The Times, which quotes daily high tide times and heights for many locations around the UK.
- o) Annual tide prediction tables for local regions are available as handy-size booklets from yacht chandlers around the UK, and from some newsagents. These too give tide heights as well as times. Tidal constants for nearby locations are also given.
- o) The Coast Guard – see your local telephone directory. Dial 999 (in the UK) in case of emergency.
- o) Posters along beach resort and harbor promenades.

Regrettably, the Automobile Association has long since stopped publishing tidal data in its Members' Handbook.

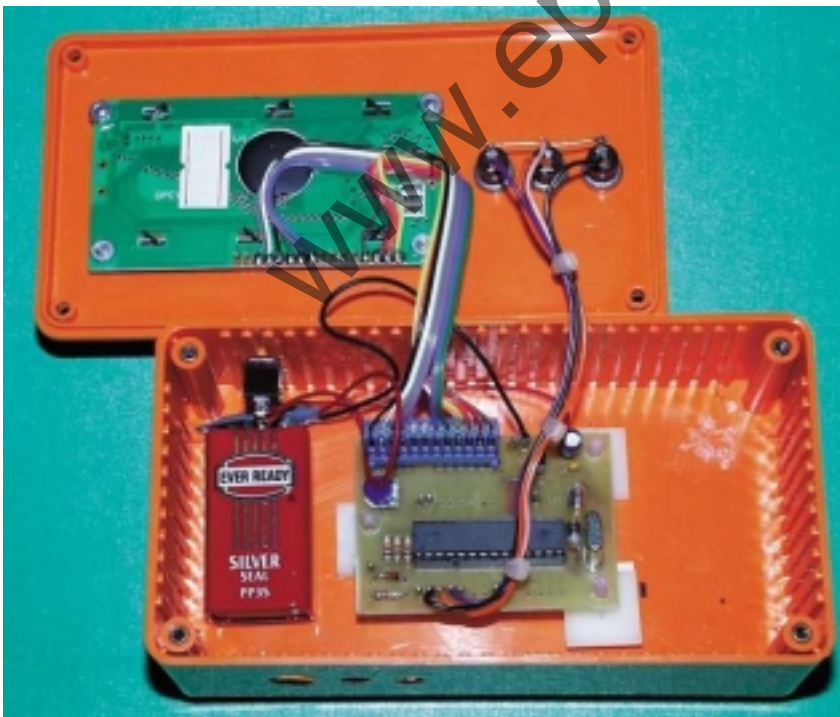

Canute Tide Predictor mounted in its case. Note that the prototype PCB differs slightly from the published version.