

Copyright © 2008, Wimborne Publishing Ltd
(Sequoia House, 398a Ringwood Road, Ferndown, Dorset BH22 9AU, UK)
and TechBites Interactive Inc.,
(PO Box 857, Madison, Alabama 35758, USA)

All rights reserved.

The materials and works contained within EPE Online — which are made available by Wimborne Publishing Ltd and TechBites Interactive Inc — are copyrighted.

TechBites Interactive Inc and Wimborne Publishing Ltd have used their best efforts in preparing these materials and works. However, TechBites Interactive Inc and Wimborne Publishing Ltd make no warranties of any kind, expressed or implied, with regard to the documentation or data contained herein, and specifically disclaim, without limitation, any implied warranties of merchantability and fitness for a particular purpose.

Because of possible variances in the quality and condition of materials and workmanship used by readers, EPE Online, its publishers and agents disclaim any responsibility for the safe and proper functioning of reader-constructed projects based on or from information published in these materials and works.

In no event shall TechBites Interactive Inc or Wimborne Publishing Ltd be responsible or liable for any loss of profit or any other commercial damages, including but not limited to special, incidental, consequential, or any other damages in connection with or arising out of furnishing, performance, or use of these materials and works.

READERS' TECHNICAL ENQUIRIES

We are unable to offer any advice on the use, purchase, repair or modification of commercial equipment or the incorporation or modification of designs published in the magazine. We regret that we cannot provide data or answer queries on articles or projects that are more than five years' old. We are not able to answer technical queries on the phone.

PROJECTS AND CIRCUITS

All reasonable precautions are taken to ensure that the advice and data given to readers is reliable. We cannot, however, guarantee it and we cannot accept legal responsibility for it. A number of projects and circuits published in EPE employ voltages that can be lethal. You should not build, test, modify or renovate any item of mains-powered equipment unless you fully understand the safety aspects involved and you use an RCD adaptor.

COMPONENT SUPPLIES

We do not supply electronic components or kits for building the projects featured; these can be supplied by advertisers in our publication Practical Everyday Electronics. Our web site is located at www.epemag.com

We advise readers to check that all parts are still available before commencing any project.



To order your copy for only \$18.95 for 12 issues go to www.epemag.com

Starter Project

STATIC FIELD DETECTOR

ROBERT PENFOLD

Amuse your friends and family with this novel "electroscope" starter project. – See if they are highly charged characters!



THIS ultra-simple device was designed as a low cost project for complete beginners, but it should also be of interest to those who like to experiment with unusual gadgets. It is a form of electroscope, which is a device that detects static electricity.

No doubt most readers have seen demonstration of purely mechanical devices that use electrostatic forces to show the presence of high static voltages. This device uses some simple electronics to detect much smaller potentials, with a twin l.e.d. display showing any increase or decrease in the detected voltage.

It has to be emphasised that this very simple unit is only intended to be a "fun" project, and it is not suitable for serious scientific purposes. Those with a serious interest in the subject of atmospheric electricity should refer to the recent *EPE* articles (*Atmospheric Electricity Detector* – June/July 2000) on this subject by Keith Garwell.

BASICS

What is the difference between static electricity and the regular variety, and why is it not possible to measure static electricity using ordinary test equipment?

In normal electronics we are concerned with a flow of electricity, with electrons moving along wires or into and out of components. Static electricity is not fundamentally different to the electrical signals we normally deal with in that it is still comprised of electrons. The difference is that the electrons are not going anywhere.

Although normal matter contains electrons, it does not necessarily have a static charge. Matter has a positive charge when it has fewer electrons than normal, or a negative charge if it has an excess of electrons.

As most readers will be aware, static charges can be generated by friction, and rubbing many plastics will generate quite high voltages. The fact that static charges are present in most environments is probably less well known. Where you are right now there could well be a potential of 50V to 100V between the air near the floor and the air about two metres higher up.

On the face of it, measuring voltages of this order should be easy enough and any multimeter should be able to handle the task. In practice matters are more complicated due to the nature of the signals involved. The voltages may be quite high, but the available current is quite low. To be more precise, an appreciable current is available, but only very briefly.

Although a digital multimeter has a high input resistance of typically over 10 megohms, this will still rapidly leak away the charge being measured. In fact, it will leak it away before a meaningful measurement can be made.

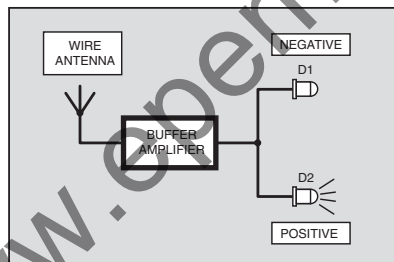

Fig.1. The static detector is basically just a buffer amplifier and two l.e.d.s.

A voltmeter having an extremely high input resistance is needed in order to measure static charges. The amount of current drawn by the test instrument is then so low that it does not significantly reduce the charge voltage during the measurement process.

Obtaining a suitably high input resistance is not difficult, since this is a natural characteristic of field effect transistors (f.e.t.s). It is also an attribute of many operational amplifiers (op.amps) which use field effect devices in their input stages. Op.amps having input resistances of one million megohms or more are commonplace, and this is more than adequate for the present application.

SYSTEM OPERATION

This Static Field Detector uses the simple arrangement shown in Fig.1. An antenna consisting of a short piece of wire is connected to the input of a buffer amplifier that

has an ultra-high input resistance. This amplifier has no voltage gain, and its sole purpose is to provide the circuit with an ultra-high input resistance. There are no bias resistors or other components at the input of the amplifier, which is therefore free to float to whatever potential the antenna assumes.

The output of the amplifier drives two l.e.d. indicators. With the output of the amplifier at about half the supply potential both l.e.d.s are switched on fairly brightly.

If the output potential rises, the brightness of l.e.d. D2 increases but l.e.d. D1 becomes dimmer and will switch off if the output potential becomes high enough. A decrease in the output voltage has the opposite effect, with D1 becoming brighter and D2 going dimmer or even switching off altogether. This method is very simple and inexpensive, but it clearly shows any variations in the detected voltage.

MEASURING WHAT?

When measuring voltages in a circuit you do not simply place one test prod on a test point and read its voltage. Most equipment is of the negative earth variety, and voltages are therefore measured relative to the negative supply rail. One test prod is connected to the earth rail (0V), and the other is placed on the test points.

Here we are effectively using a single test prod in the form of the antenna, with voltage measurements being made relative to nothing. Although it might seem as though the same middle reading will always be obtained, this is not actually the case.

When the unit is first switched on the two l.e.d.s will switch on to indicate a middle voltage. If the unit is moved around the l.e.d.s should soon start to indicate changes in potential. The unit is registering changes in voltage relative to the antenna's starting potential. It would be possible to connect the negative supply rail of the unit to an earth and then make measurements relative to the earth's potential.

However, a simple circuit such as this can only handle an input voltage range of about 0V to 9V, whereas signals of either polarity and up to a few hundred volts in magnitude might be encountered. Also, using an earth is relatively awkward and restrictive. The method used here is freer, easier, and works quite well.

CIRCUIT OPERATION

The full circuit diagram for the Static Field Detector appears in Fig.2. The

operational amplifier, IC1, is the buffer amplifier, and is a bi-f.e.t. device that uses junction gate field effect transistors in its input stage. A device having a MOSFET input stage should work equally well on the input side of things, as should any other bi-f.e.t. op.amp.

The specified TL061CP op.amp has an output stage that will drive both l.e.d.s from fully switched off to fully switched on, whereas most other op.amps will fail to do this. Consequently, the use of alternative devices is not recommended.

No voltage gain is required in this application, so 100 per cent negative feedback is provided by coupling the output of the amplifier (pin 6) to the inverting input (pin 2) via resistor R1. The output adopts the same voltage as the non-inverting input at pin 3, but there is a massive current gain through IC1.

The input current is probably a few nanoamps or even picoamps, but the output can provide a few milliamps to drive the l.e.d.s at good brightness. Resistors R2 and R3 limit the current fed to l.e.d.s D1 and D2 to a safe level.

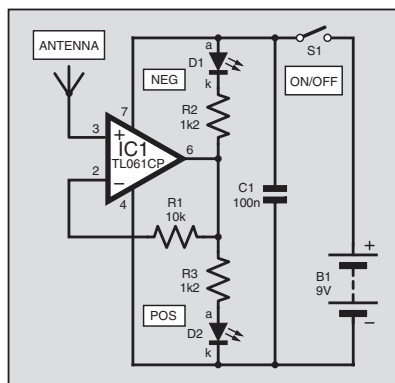

Fig.2. Complete circuit diagram for the Static Field Detector.

The maximum drive current is about 5mA. The TL061CP used for IC1 is a low current device, and the current consumption of the circuit as a whole is never much more than about 5mA.

CONSTRUCTION

The construction of the Static Field Detector is based on the *EPE* multi-project printed circuit board. This board is available from the *EPE PCB Service*, code 932. The component layout, wiring and the actual size foil master pattern are shown in Fig.3.

Although there are very few components to fit onto the circuit board, the usual warning is still in order here. Unlike a normal custom printed circuit board, this board does not have one hole per component lead. It has many holes that are left unused, and the small number of components used in this circuit means that the vast majority of them are not used.

The low component count actually makes it easier to make a mistake, so it is essential to take more care than normal when fitting the components. Also, carefully check the completed board for errors.

In all other respects construction of the board offers nothing out of the ordinary. The TL061CP used for IC1 is not a device that is vulnerable to damage from static charges, but it is still advisable to mount it on the board via an i.c. socket.

There are two ways of dealing with the l.e.d.s. One is to mount them in panel holders and then hard wire them to the circuit board. The board should be fitted with single-sided solder pins at the points where the connections to the two l.e.d.s will be made. Incidentally, it should also be fitted with pins at the points where connections will be made to on/off switch S1, the battery, and the antenna.

Finished handheld detector showing labelling of the two "static" l.e.d.s.



The alternative method is to mount the l.e.d.s D1 and D2 on the printed circuit board, and to leave the leadout wires quite long. With the printed circuit board mounted on the base panel of the case, the l.e.d.s will then fit into two 5mm dia. holes drilled at the appropriate positions in the top panel.

Note that l.e.d.s, unlike filament bulbs, will only operate if they are connected with the correct polarity. The cathode (k) lead-out wire is normally shorter than the anode (a) lead. Also, most l.e.d.s. have a "flat" on the component's body, next to the cathode lead.

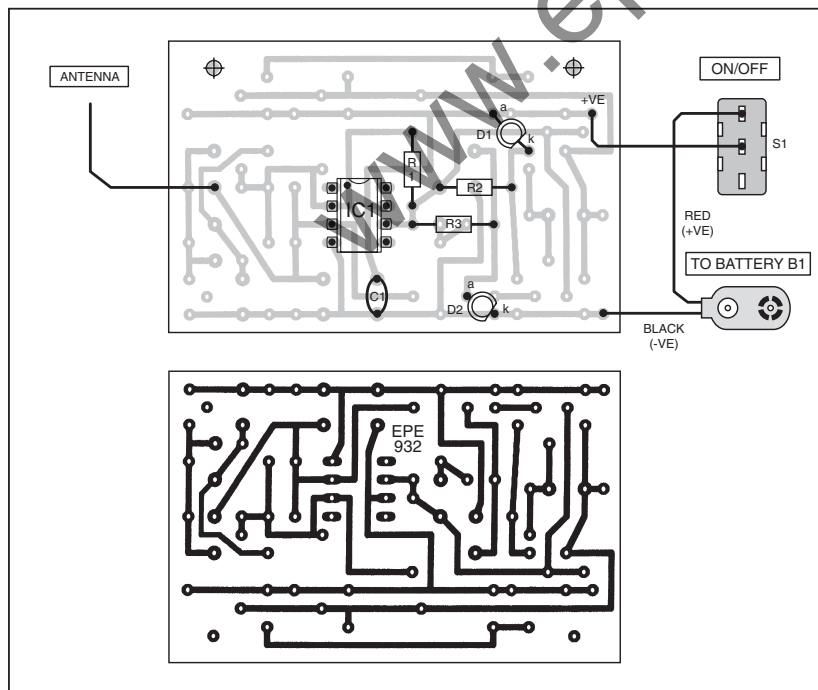

Fig.3. Component layout on the multi-project printed circuit board and full-size copper foil master. Double-check layout as not all holes are used.

COMPONENTS

Resistors

R1 10k
R2, R3 1k2 (2 off)

All 0.25W 5% carbon film

Capacitor

C1 100n ceramic

Semiconductors

D1, D2 5mm panel l.e.d.s, red
IC1 TL061CP (see text)

Miscellaneous

S1 s.p.s.t. min toggle switch
B1 9V battery (PP3 size)

Small plastic case, size to choice; printed circuit board available from the *EPE PCB Service*, code 932; battery connector; stout tinned copper wire for antenna; plastic stand-off pillars or M3 nuts and bolts (see text); single-sided solder pins (3 off); solder, etc.

Approx. Cost
Guidance Only

£10

CASING-UP

Any small to medium size plastic case is suitable for this project. It is best not to use a metal box as it could interfere with the correct operation of the device, and would complicate fitting the antenna.

The completed printed circuit board is mounted inside the case using either plastic stand-offs or metric M3 bolts and fixing nuts. If bolts are used, spacers a few millimetres long must be fitted between the case and the board.

On/off switch S1 is mounted at any convenient point on the case, and a hole about 2mm dia. is drilled in the top side panel of the case, see photographs. This hole is for the antenna, which is merely a piece of tinned copper wire that protrudes about 75mm to 100mm beyond the front of the case. This wire should be fairly thick, but anything from about 0.7mm to 1.6mm (22 to 16s.w.g.) is suitable.

To complete the unit add the battery connector, fit the antenna, and add the wire from S1 to the circuit board.

TESTING

Start with the lid of the case removed so that you have access to the circuit board.

Both l.e.d.s should light up quite brightly when the unit is switched on. Try touching the antenna and the solder pin on the circuit board that takes the connection from the negative (black) battery lead. This should result in l.e.d. D2 switching off and D1 increasing in brightness.

Next touch the antenna and the solder pin that takes the lead from S1. This should have the opposite effect, with l.e.d. D1 switching off and D2 lighting more brightly. If there is any sign of a malfunction switch off at once and recheck the circuit board, etc.

If all is well, refit the lid of the case and make some initial tests with the detector. In general, there is more to detect in a dry atmosphere than in a humid one where charges tend to leak away. Up and down movement will usually produce some change in the display.

Placing the unit near the ground invariably produces a strong positive indication, as will placing the antenna near anything that is earthed. This includes things like the metal case of a computer, a radiator, or the walls of a house.

You can amuse you friends and family by checking to see if they are highly charge

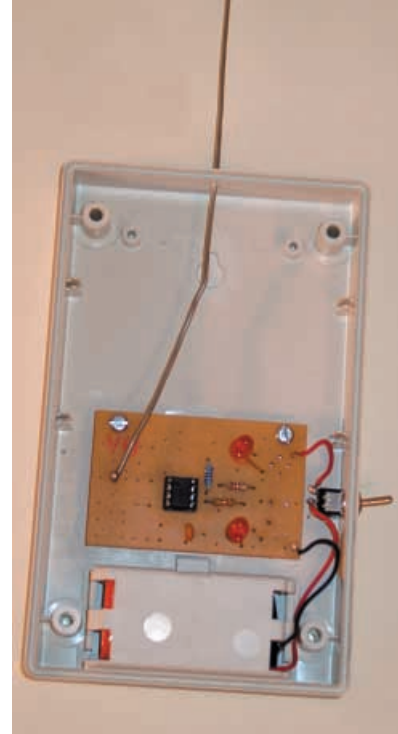

The simple layout of components inside the handheld case.

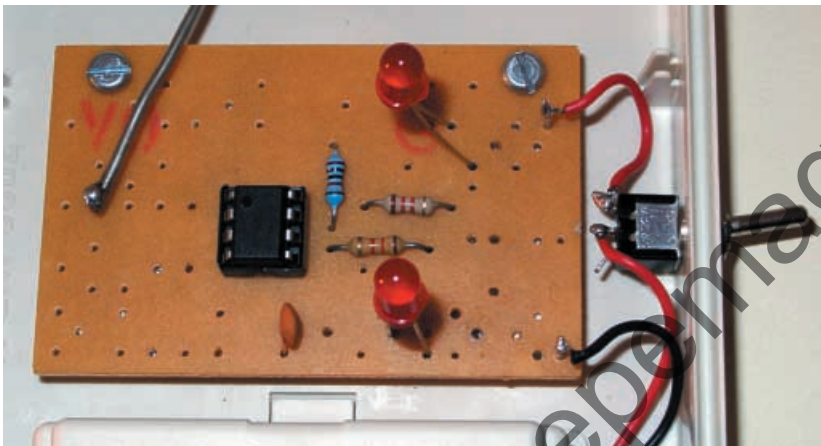

Completed circuit board. Note the unused holes.

characters, and whether they emit positive or negative energy. Get them to rub their clothes and then try again to see if different results are obtained.

The device used for IC1 has built-in protection circuitry that should prevent the input voltage from going outside the range that the unit can handle. If the l.e.d.s seem to get stuck showing a fully positive or negative indication try switching off, waiting a second or two, and then switching on again.

Attempts to deliberately “zap” IC1 by placing the antenna near known sources of high static voltages such as television screens proved fruitless. This suggests that the unit is reasonably “zap” resistant, but large static charges *can* destroy most modern semiconductors, so you try this sort of thing at your own risk. □

★ MAKE IT A SPECIAL GIFT EVERY MONTH ★

EVERYDAY
PRACTICAL
ELECTRONICS

INCORPORATING **ELECTRONICS TODAY INTERNATIONAL**
THE No.1 MAGAZINE FOR ELECTRONICS TECHNOLOGY & COMPUTER PROJECTS

SUBSCRIPTION ORDER FORM



I enclose payment of £..... (cheque/PO in £ sterling only), payable to Everyday Practical Electronics



Access or Visa No.

--	--	--	--	--	--	--	--	--	--	--	--	--	--	--	--	--	--	--	--

Signature.....

Card Ex. Date

Please supply name and address of cardholder if different from the subscription address shown below. **Subscriptions can only start with the next available issue.** For back numbers see the Editorial page.

Annual subscription rates (2000/2001):

6 Months: UK £14.50, Overseas £17.50 (standard air service), £27 (express airmail)

1 Year: UK £27.50, Overseas £33.50 (standard air service) £51 (express airmail)

2 Years: UK £50.00, Overseas £62.00 (standard air service) £97 (express airmail)

To: Everyday Practical Electronics,
Allen House, East Borough, Wimborne, Dorset BH21 1PF
Tel: 01202 881749 Fax: 01202 841692
E-mail: subs@epemag.wimborne.co.uk

Name

Address

.....

.....Post code

12/00