

Copyright © 2008, Wimborne Publishing Ltd
(Sequoia House, 398a Ringwood Road, Ferndown, Dorset BH22 9AU, UK)
and TechBites Interactive Inc.,
(PO Box 857, Madison, Alabama 35758, USA)

All rights reserved.

**The materials and works contained within EPE Online — which are made available by
Wimborne Publishing Ltd and TechBites Interactive Inc — are copyrighted.**

TechBites Interactive Inc and Wimborne Publishing Ltd have used their best efforts in preparing these materials and works. However, TechBites Interactive Inc and Wimborne Publishing Ltd make no warranties of any kind, expressed or implied, with regard to the documentation or data contained herein, and specifically disclaim, without limitation, any implied warranties of merchantability and fitness for a particular purpose.

Because of possible variances in the quality and condition of materials and workmanship used by readers, EPE Online, its publishers and agents disclaim any responsibility for the safe and proper functioning of reader-constructed projects based on or from information published in these materials and works.

In no event shall TechBites Interactive Inc or Wimborne Publishing Ltd be responsible or liable for any loss of profit or any other commercial damages, including but not limited to special, incidental, consequential, or any other damages in connection with or arising out of furnishing, performance, or use of these materials and works.

READERS' TECHNICAL ENQUIRIES

We are unable to offer any advice on the use, purchase, repair or modification of commercial equipment or the incorporation or modification of designs published in the magazine. We regret that we cannot provide data or answer queries on articles or projects that are more than five years' old. We are not able to answer technical queries on the phone.

PROJECTS AND CIRCUITS

All reasonable precautions are taken to ensure that the advice and data given to readers is reliable. We cannot, however, guarantee it and we cannot accept legal responsibility for it. A number of projects and circuits published in EPE employ voltages that can be lethal. You should not build, test, modify or renovate any item of mains-powered equipment unless you fully understand the safety aspects involved and you use an RCD adaptor.

COMPONENT SUPPLIES

We do not supply electronic components or kits for building the projects featured; these can be supplied by advertisers in our publication Practical Everyday Electronics. Our web site is located at www.epemag.com

We advise readers to check that all parts are still available before commencing any project.



To order you copy for only \$18.95 for 12 issues go to www.epemag.com

Constructional Project

CAMERA SHUTTER TIMER

by ROBERT PENFOLD

An easy-to-build project that will check your camera shutter speeds. Four switched ranges up to: 5ms; 50ms; 500ms and 5 seconds.

Although digital cameras have been progressing rapidly in recent years, and most of the photographs in this magazine are now produced without the aid of film, most people are still using traditional cameras. It seems likely that they will continue to do so for some years yet.

The quality of the finished result with traditional photography is dependent on a number of factors. One of these is the accuracy of the shutter, which is particularly important when using certain types of film. There is very little exposure latitude with any form of transparency film, and also with certain negative films.

Modern SLR cameras mostly have electronically timed shutters, and in terms of accuracy they are generally superior to the purely mechanically shutters of older designs. Electronically timed shutters are also less prone to

creeping out of adjustment over a period of time, but things can obviously go awry with shutters of either variety.

ON TIME

It is not essential to use a complex digital timer to test camera shutters, and a very basic analogue timer circuit is capable of providing accurate measurements in this application. The simple design featured here has four measuring ranges having full-scale values of 5ms, 50ms, 500ms, and 5 seconds. It can therefore be used to measure the full range of speeds covered by most cameras.

Some of the more modern cameras have manual shutter speeds of up to around 30 seconds or so, which takes the longer shutter speeds beyond the maximum range of this unit.

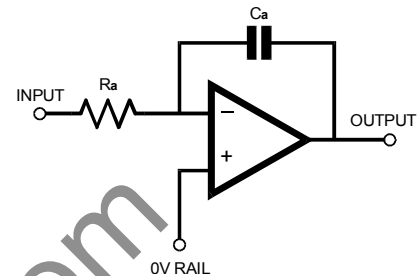

Fig.1. The basic integrator circuit.

However, these longer shutter times of around 8 seconds to a minute are easily tested using a stopwatch, and do not really need a shutter timer.

Although this unit is primarily designed for testing shutters, it should be possible to modify it for use in some other automatic timing applications. The light level on a sensor going above a certain threshold level activates the timer, but it can also be controlled by switch contacts.

INTEGRATOR

The circuit is based on an operational amplifier (opamp) connected as an integrator. The basic integrator circuit is shown in Fig.1. Like most basic operational amplifier building blocks an integrator requires dual (positive and negative) supply rails with a central (zero volt) earth rail. The inputs and outputs can therefore have negative as well as positive voltage levels.

An operational amplifier amplifies the voltage difference



at its two inputs, and the output voltage is positive if the non-inverting (+) input is at the higher potential. The output voltage is negative if the inverting (-) input is at the higher voltage. The voltage gain is extremely high at DC and low frequencies, with a figure of around 200,000 being unexceptional.

Under standby conditions, the non-inverting (+) input is biased to the 0V rail, and there is no charge on capacitor Ca. A negative feedback action stabilizes the inverting input at the 0V bias level fed to the non-inverting input.

If the output was at a positive potential, the coupling through Ca (which has no charge voltage) would take the inverting input positive, unbalancing the input voltages and taking the output negative. With the output at a negative voltage the feedback through Ca again unbalances the input levels, and this time sends the output positive. Any drift in the output voltage is therefore corrected by the feedback.

With a real world opamp the output will not be stabilized at precisely 0V, since the gain of the amplifier is very high rather than infinite. Also, imperfections in the opamp's circuit can produce small offset voltages at the output, but in practice any errors are normally very small.

ON CHARGE

So far we have only considered the circuit with the input "floating" or at 0V. Suppose that the input is taken a few volts positive. Capacitor Ca then charges through resistor Ra, and the voltage at the inverting input starts to rise.

This sends the output

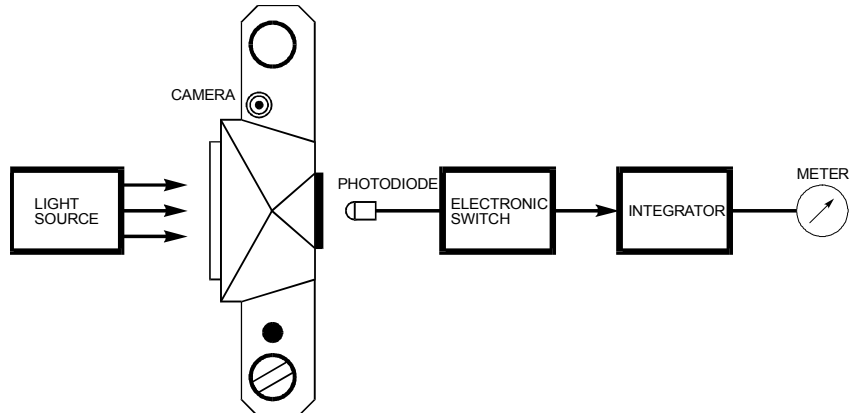
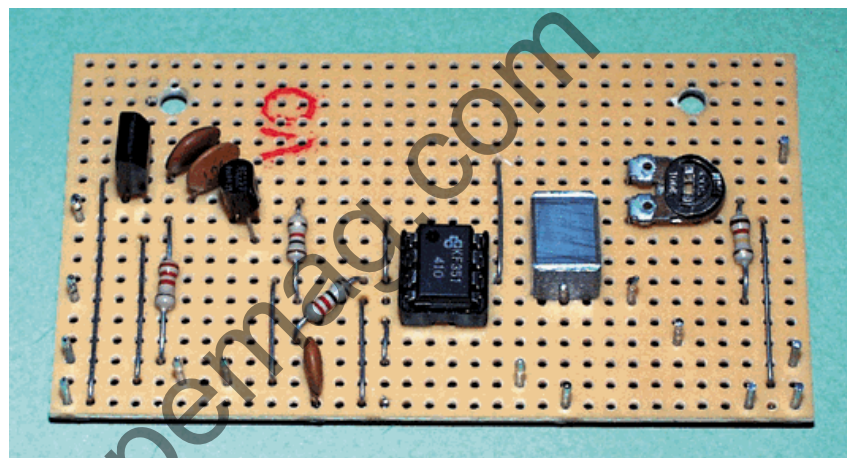

Fig.2. Block schematic diagram for the Camera Shutter Timer.



COMPONENTS

Resistors

- R1 1k
- R2 2k2
- R3 2k7
- R4 27k
- R5 270k
- R6 2M7
- R7 22 ohms
- R8 120k

All 0.25W 5% carbon film except where noted

Potentiometers

- VR1 220k rotary carbon (linear)
- VR2 100k miniature carbon preset, horizontal

Capacitors

- C1, C2, C4 100n disc ceramic (3 off)
- C3 1u polyester, 10mm lead spacing

See also the
SHOP TALK Page!

Semiconductors

- D1 SFH309/5 phototransistor or other small phototransistor/diode (see text)
- TR1 BC559 *pnp* transistor
- IC1 78L05 +5V 100mA voltage regulator
- IC2 LF351N biFET opamp

Miscellaneous

- S1 4-way 3-pole rotary switch (only one pole used)
- S2 pushbutton switch, push-to make release-to-break
- S3 d.p.s.t. miniature toggle or rotary switch
- ME1 50uA FSD moving coil panel meter
- B1, B2 9V batteries, PP3 size (2 off)

Metal instrument case, size about 200mm wide; 0.1 inch matrix stripboard having 33 holes by 18 strips; 8-pin DIL socket; battery connector (2 off); control knob (3 off); multistrand connecting wire; screened lead; single-ended solder pins;

Approx. Cost
Guidance Only

(Excluding meter, case, batts)

\$19

negative in order to keep the inverting input at 0V. As C_a charges, the inverting input remains at 0V and the output of the circuit goes steadily more negative.

The important point to note here is that the voltage across resistor R_a remains constant, and is equal to the input voltage. The current flow through R_a , and therefore the charge current for C_a , is also constant.

If a capacitor is simply charged from a resistor via a voltage source, the voltage rises quickly initially, but then gradually slows down. This is due to the fact that there is initially the full voltage across the resistor, giving a high charge current. As the voltage across the capacitor rises, the voltage across the resistor falls, giving an ever-decreasing charge rate.

The constant current flow into C_a results in the output of the circuit going negative at a linear rate. If the output is at -1V after one second, it will be at -2V after two seconds, -3V after three seconds, and so on.

An integrator is therefore ideal as the basis of a simple timer. It is just a matter of using a voltmeter circuit at the output and adjusting the scaling so that the meter readings are easily converted into times.

SPEED AND SIZE

The block diagram of Fig.2 shows the general scheme of things used in the *Camera Shutter Timer* project. The integrator drives a moving coil panel meter, with the later directly indicating shutter timers over the four ranges stated previously. Using four input resistors, giving four different charge rates for the capacitor, provides the four ranges.

The integrator is driven from

a photodiode or a phototransistor via an electronic switch. It is essential to use a photocell that has a fast response time since most cameras have a faster shutter time of one millisecond or less. Photo-resistors are too slow, but phototransistors and photodiodes have suitably fast response times.

In theory there is some advantage in using a photodiode due to its faster response time. In practice a photodiode seems to provide little improvement in accuracy in this application. Also, a photodiode has the drawback of being far less sensitive than a phototransistor. This design incorporates a simple transistor switching stage to ensure that the integrator receives a proper switching signal whether a photodiode or a phototransistor is used.

On the face of it, the size of the sensor is unimportant, but in this application it is a case of "small is beautiful". The design of mechanical shutters has to take into account the fact that it takes a certain amount of time for the shutter to open and close.

At the slow speeds this factor does not matter because the opening and closing times are very short relative to the shutter time. At the fastest shutter speeds the opening and closing times can actually be longer than the nominal shutter speed. This may seem to be impossible, but all becomes clear when the action of a focal-plane shutter is examined.

CURTAIN CALL

There are two shutter curtains that are made from metal or rubberized cloth. One of the curtains blocks light from the film until the shutter is fired, and then it slides out of the way to one side to expose the film. After the appropriate time, the second curtain moves across the film

gate and blocks light from reaching the film again. The two curtains are then pulled back to their original positions, and they move together in such away that light is always blocked from the film. The shutter is then ready to operate again.

As it takes several milliseconds for each curtain to traverse the film gate, the only way of achieving fast shutter speeds is to start the second shutter curtain before the first one has completely moved out of the way. This effectively gives a slit that travels across the film, exposing it a bit at a time. The faster the shutter speed, the narrower the slit is made. Although it may take something like 10 milliseconds for the shutter to complete an exposure, by making the slit narrow enough each part of the film can be exposed for a millisecond or even less.

Here we are measuring the shutter time by having a light source in front of the shutter, and the sensor positioned behind it and quite close to the film plane, see Fig.2. The unit responds to the pulse of light produced when the shutter is fired. If the sensor has a large diameter its size effectively increases the size of the slit when the shutter is used at fast speeds, giving elongated shutter timings. For this type of measurement the sensor would ideally be only a fraction of a millimeter in diameter, but it also needs to be reasonably sensitive.

In practice a diameter of about one millimeter is a good compromise. Photodiodes and phototransistors as small as this seem to be unobtainable these days, but a larger device is easily masked to produce an effective diameter of about one millimeter.

CIRCUIT OPERATION

The full circuit diagram for the *Camera Shutter Timer* is shown in Fig.3. Operational amplifier IC2 is used in the integrator mode, and capacitor C3 is the integration capacitor. Resistors R3 to R6 are the input Range resistors, and the required resistor is selected using Range switch S1.

Meter ME1 is driven from the output of IC2 (pin 6) via the series resistance of R8 and calibration preset potentiometer VR2. Operating Reset switch S2 discharges capacitor C3 through current limiter resistor R7 so that the meter is zeroed and a new reading can be taken. Resistor R7 prevents excessive discharge currents that would otherwise shorten the operating life of switch S2.

Under dark conditions, photodiode D1 operates much like any other semiconductor diode. When reverse biased, as it is here, only a minute leakage current flows. Under bright conditions the leakage level increases, and the leakage current is roughly proportional to the received light level.

If the leakage current is high enough, transistor TR1 is biased into conduction and it applies +5V to the input of the integrator. In practice, sensitivity or Level control VR1 is adjusted so that TR1 is switched off when the shutter is closed, and turned on when the shutter is open. Potentiometer VR1 enables the unit to function properly under a wide range of ambient light levels.

Operation using a phototransistor is much the same, and Fig.3 shows the correct method of connection for a component of this type. Under dark conditions the collector (c) to emitter (e) leakage current is

the low level associated with ordinary silicon transistors, but at high light intensities it rises to a milliamp or more. This again gives the required on/off switching action from TR1.

It is important that the integrator is fed with a stable input potential since any changes in this voltage will alter the charge current of the integration capacitor and degrade the accuracy of the unit. A monolithic voltage regulator (IC1) is therefore used to produce a well-stabilized +5V supply for the input circuitry.

The integrator, IC2, does not require a stabilized supply and is powered direct from two small (PP3 size) 9V batteries. The current consumption is only a few milliamps from each supply rail.

CONSTRUCTION

Most of the components are assembled on a piece of stripboard that has 33 holes by 18 copper strips. The component layout, interwiring and details of the breaks required in the underside copper strips are shown in Fig.4.

Construction of the board follows along normal lines, with a board being trimmed down to the correct size using a hacksaw, the two 3mm diameter mounting holes then being drilled, after which the 12 breaks in the copper strips are cut. The breaks can be made using a handheld twist drill bit of about 5mm diameter or so. The board is now ready for the components and link wires to be added. The LF351N specified for IC2 is not a static-sensitive component, but it is still a good idea to use a holder for this component. Do not overlook any of the eight link wires.

The shorter links can be made from the wire trimmed from resistors, but some 22s.w.g. or 24s.w.g. tinned copper wire is needed for the longer links. At this stage only fit single-sided solder pins to the board at the positions where connections to the meter, controls, etc. will eventually be made.

BOXING-UP

When choosing a case for this project, bear in mind that a fair amount of front panel space is required for the meter and four controls. This precludes the use of small and most medium size cases. A metal instrument case about 200mm or so wide is probably the best choice and was used for the prototype, but one of the larger plastic boxes would also be suitable.

The exact component layout used is not important from the electrical point of view, since the circuit operates at DC and is not prone to problems with stray feedback or noise pick up. However, try to use a sensible layout that makes the unit easy to use.

PANEL METER

Fitting the meter on the front panel is potentially difficult, as it requires a large round mounting hole. This is 38mm in diameter for most of the smaller meters, but it is clearly advisable to check this before cutting the hole.

The quickest way of making this cutout is to use a hole-cutter of the appropriate diameter, or to use one of the adjustable cutters that are available from most do-it-yourself superstores. Alternatively, cutting carefully using a coping saw, Abrafile, or any similar tool will produce the

cutout, albeit rather slowly.

Four 3mm diameter mounting holes are required for the threaded rods built into the meter. These are normally at the corners of a square having 32mm sides and the same center as the main mounting hole. Again, it is advisable to make some measurements on the meter itself to check its mounting arrangements prior to drilling any holes.



Finished unit showing front panel layout and lettering. Note the phototransistor/diode light sensor is attached to the free end of the screened cable.

LIGHT SENSOR

Photodiode D1 can be connected to the main unit via a two-way plug and socket such as a 3.5mm jack type, but it is cheaper and easier to simply hard wire it to the circuit board. A hole for the connecting cable must be drilled in the case, and the hole should be fitted with a grommet to protect the cable if the case is a metal type.

A piece of two-way cable

about 0.5 meters long is used to connect light sensor D1 to the circuit board, and low cost screened cable is probably the best choice. Use the outer braiding to connect the anode (or emitter) to the 0V rail, and the inner lead to connect the cathode (or collector) to resistor R2.

The unit worked when tried

with various photodiodes and phototransistors, but as explained previously, results will be more accurate at faster shutter speeds if a sensor having a diameter of 3mm or less is used. Results will be even better if the sensor is masked down to a diameter of about one millimeter, and the easiest way of doing this is to

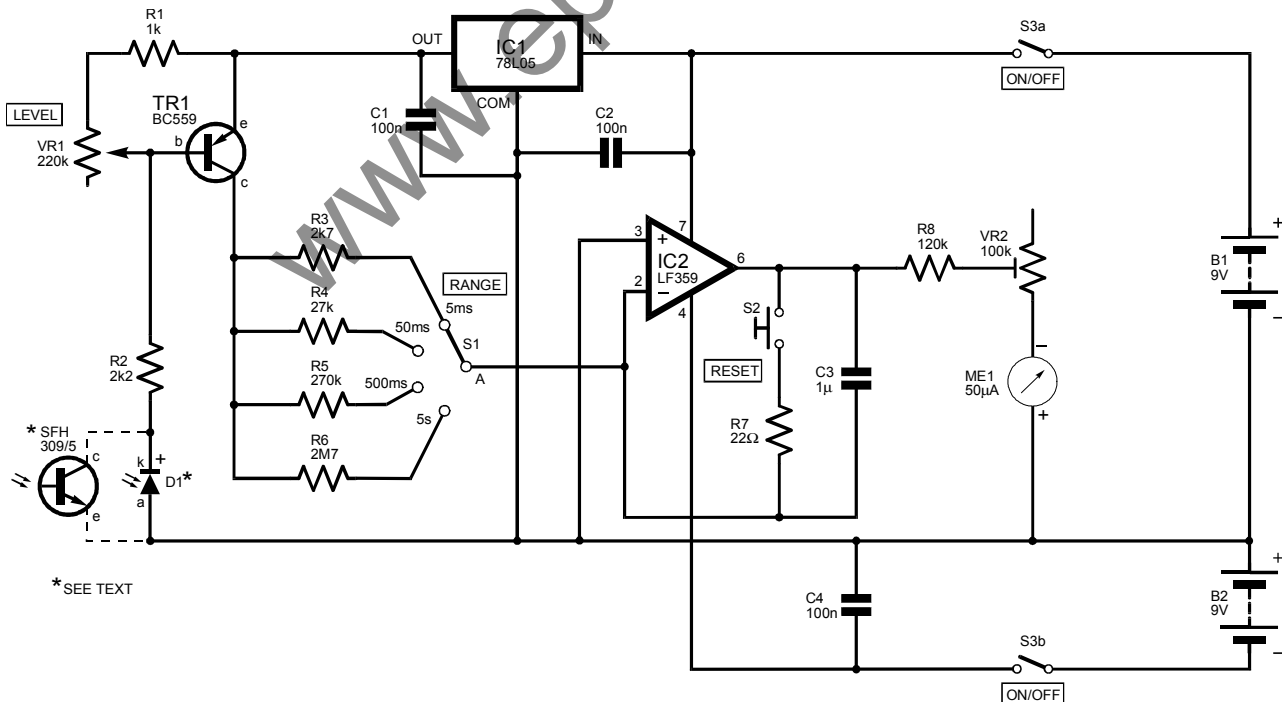

Fig.3. Complete circuit diagram for the Camera Shutter Timer. Note S3 is a "ganged" double-pole switch.

apply a ring of black paint around the front of the diode.

FINAL ASSEMBLY

The circuit board is mounted on the base panel of the case, well towards the right-hand side, as viewed from the rear, so that there is sufficient space for the batteries to its left, see photograph. Mounting bolts are preferable to plastic stand-offs when using stripboard, and both 6BA and metric M3 bolts are suitable. Include spacers at least 6mm long to hold the underside of the board well clear of the case.

All the hard wiring is included in Fig.4 and is largely straightforward. Be careful to connect meter ME1 and the two

battery connectors with the correct polarity. If sensor D1 has a standard light-emitting diode (LED) style case, the shorter leadout wire will be the cathode or the collector. For diodes having other case styles the manufacturer's or retailer's literature should be consulted.

The base terminal is not normally accessible on small phototransistors, but if there is a base lead it is simply ignored.

The four range resistors (R3 to R6) should be mounted directly on the rotary Range selector switch S1. It is best to solder the resistors on the switch tags before it is fitted in the case front panel.

Try to complete the soldering fairly swiftly so that the

Table 1: Equivalent times in milliseconds for shutter speeds.

Marked Speed	Equivalent in ms
1/4000	0.25
1/2000	0.5
1/1000	1
1/500	2
1/250	3
1/125	8
1/60	16.66
1/30	33.33
1/15	66.66
1/8	125
1/4	250
1/2	500
1	1000

resistors do not overheat. It takes quite a lot of heat to destroy them, but relatively small amounts to impair their accuracy.

CALIBRATION AND TESTING

Start calibration/testing with Range switch S1 set to the five-second range (R6 switched into circuit) and preset VR2 adjusted to roughly middle setting. When the unit is

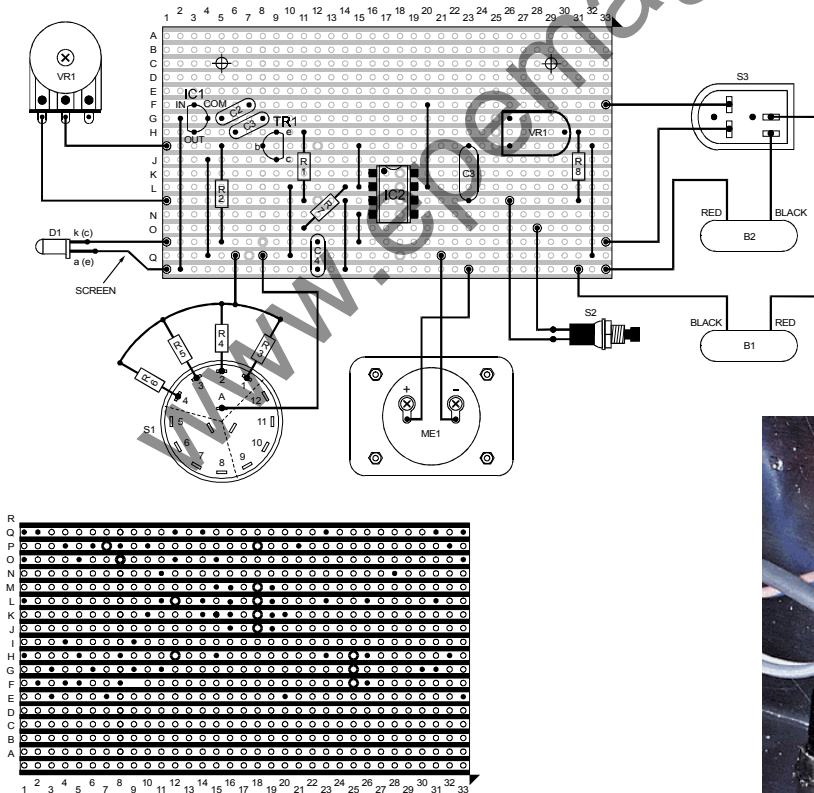
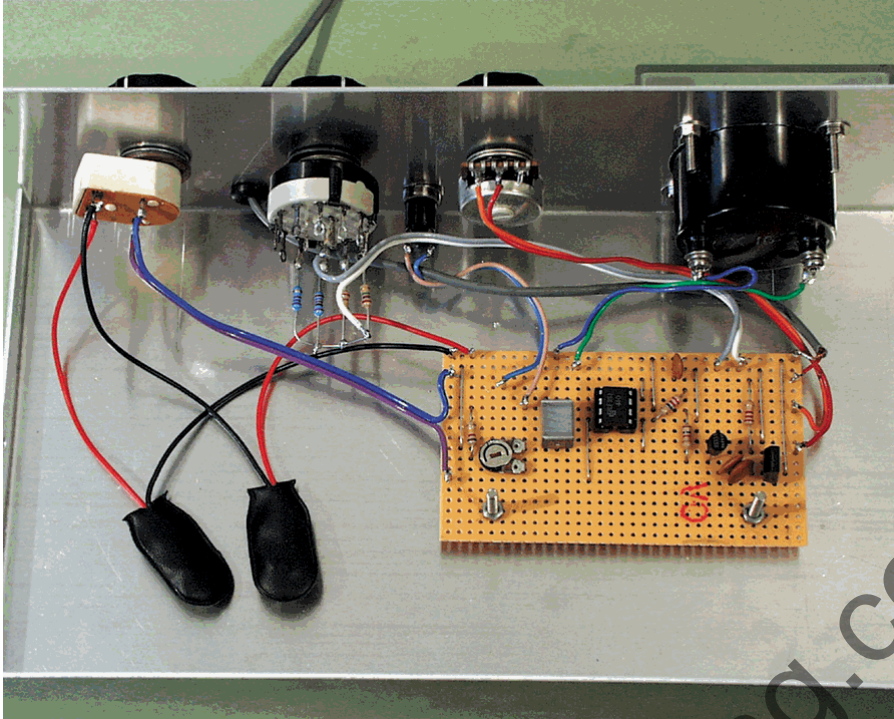

Fig.4. Camera Shutter Timer stripboard component layout, inter-wiring and details of breaks required in the underside copper strips. (Right) Mounting the Range resistors directly on the switch tags before it is fitted in the case will help with the final wiring.





Layout of components inside the prototype metal case. The circuit board is bolted to one side of the case to make space for the batteries. The board should be bolted on 6mm spacers to keep the copper underside well clear of the metal case.

first switched on the meter ME1 may read other than zero, but briefly pressing pushswitch S2 should zero the meter.

With the sensor (D1) aimed towards a light source, which can simply be bright daylight coming through a window or light from a table lamp, the meter reading should slowly advance. However, it may require some adjustment to Level control VR1 before this happens. Clockwise adjustment of VR1 reduces the light level needed to activate the unit. If the sensor is a photodiode a reasonably strong light source will be required.

With a little trial and error it should be possible to find a setting that results in the meter reading advancing when the sensor is aimed towards the light source, and stopping when it is not. If the unit seems to be

malfunctioning in any way, switch off immediately and recheck the entire wiring, etc.

It might be possible to check automatic exposure times with some cameras, but the unit was only designed to check manual speeds. Obviously the timer is only usable with cameras that have removable or hinged backs, which means the vast majority of 35mm models.

The main exceptions are some of the older Leica models and copies of these such as the early Fed and Zorki cameras. The timer was not designed to test "leaf" shutters, but it seemed to work quite well when used with shutters for large format lenses and when tried with some "golden oldies", such as an Agfa Rangefinder model.

Testing is easier if the lens is removed from the camera, but it is possible to make accurate

measurements with cameras that have fixed lenses. A large light source such as a window is then preferable. This minimizes any dark areas where there will be insufficient light to activate the sensor.

Results are best with the sensor positioned quite close to the shutter curtains, but great care must be taken to avoid getting the sensor in contact with any part of the shutter. These days the cost of having damaged shutters repaired is so high that the sums involved are higher than the value of the repaired cameras. Therefore, it is better to err on the side of caution and have a gap of several millimeters between the shutter and the sensor.

The best way of calibrating the unit is to use a recently manufactured or serviced camera as the calibration source. Set the timer to the 500-millisecond range and the camera for a shutter speed of 0.5 seconds (500 milliseconds).

Press Reset switch S2 to zero the meter, take a reading, and then adjust preset VR2 for precisely full-scale reading on the meter. In the absence of a suitably reliable camera, calibrate the unit on the five-second range using the camera set to "bulb" or "B", and a stopwatch to help generate a five second shutter time.

The 0 to 50 scaling of the specified meter produces readings that are easily converted into shutter times, and it is not worthwhile doing any recalibration. Cameras use shutter times expressed as fractions of a second rather than in milliseconds, which slightly complicates matters. However, Table 1 shows the equivalent

times in milliseconds for the standard shutter speeds.

IN USE

It is only fair to point out that the generally accepted camera standards allow for quite large margins of error, especially on

the faster shutter speeds. An error of something like +50 percent is clearly not good, but it does not indicate a faulty shutter, just one having mediocre accuracy.

With older cameras do not

be surprised if checking the same shutter setting produces a fairly wide range of times. Unless the variations are very wide this does not indicate that the shutter is faulty, but it does suggest that it is long overdue for cleaning and recalibration.

N. R. BARDWELL LTD (EPE)		
180	Signal Diodes 1N4148	£1.00
73	Rectifier Diodes 1N4001	£1.00
65	Rectifier Diodes 1N4007	£1.00
16	Wet Bridge Rectifiers	£1.00
16	555 Timer I.C.s	£1.00
4	741 Op Amps	£1.00
65	Assorted Zener Diodes 400mW	£1.00
13	Assorted 7-segment Displays	£1.00
25	5mm L.e.d.s, red, green or yellow	£1.00
25	3mm L.e.d.s, red, green or yellow	£1.00
65	Assort. L.e.d.s, Small red Diode Package	£1.00
26	Assort. High Brightness L.e.d.s, red color	£1.00
26	BC107 Transistors	£1.00
26	BC177 Transistors	£1.00
26	BC220 Transistors	£1.00
26	BC237 Transistors	£1.00
26	BC239 Transistors	£1.00
26	BC236 Transistors	£1.00
26	BC235 Transistors	£1.00
26	BC234 Transistors	£1.00
26	BC233 Transistors	£1.00
26	BC232 Transistors	£1.00
26	BC231 Transistors	£1.00
26	BC230 Transistors	£1.00
26	BC229 Transistors	£1.00
26	BC228 Transistors	£1.00
26	BC227 Transistors	£1.00
26	BC226 Transistors	£1.00
26	BC225 Transistors	£1.00
26	BC224 Transistors	£1.00
26	BC223 Transistors	£1.00
26	BC222 Transistors	£1.00
26	BC221 Transistors	£1.00
26	BC220 Transistors	£1.00
26	BC219 Transistors	£1.00
26	BC218 Transistors	£1.00
26	BC217 Transistors	£1.00
26	BC216 Transistors	£1.00
26	BC215 Transistors	£1.00
26	BC214 Transistors	£1.00
26	BC213 Transistors	£1.00
26	BC212 Transistors	£1.00
26	BC211 Transistors	£1.00
26	BC210 Transistors	£1.00
26	BC209 Transistors	£1.00
26	BC208 Transistors	£1.00
26	BC207 Transistors	£1.00
26	BC206 Transistors	£1.00
26	BC205 Transistors	£1.00
26	BC204 Transistors	£1.00
26	BC203 Transistors	£1.00
26	BC202 Transistors	£1.00
26	BC201 Transistors	£1.00
26	BC200 Transistors	£1.00
26	BC199 Transistors	£1.00
26	BC198 Transistors	£1.00
26	BC197 Transistors	£1.00
26	BC196 Transistors	£1.00
26	BC195 Transistors	£1.00
26	BC194 Transistors	£1.00
26	BC193 Transistors	£1.00
26	BC192 Transistors	£1.00
26	BC191 Transistors	£1.00
26	BC190 Transistors	£1.00
26	BC189 Transistors	£1.00
26	BC188 Transistors	£1.00
26	BC187 Transistors	£1.00
26	BC186 Transistors	£1.00
26	BC185 Transistors	£1.00
26	BC184 Transistors	£1.00
26	BC183 Transistors	£1.00
26	BC182 Transistors	£1.00
26	BC181 Transistors	£1.00
26	BC180 Transistors	£1.00
26	BC179 Transistors	£1.00
26	BC178 Transistors	£1.00
26	BC177 Transistors	£1.00
26	BC176 Transistors	£1.00
26	BC175 Transistors	£1.00
26	BC174 Transistors	£1.00
26	BC173 Transistors	£1.00
26	BC172 Transistors	£1.00
26	BC171 Transistors	£1.00
26	BC170 Transistors	£1.00
26	BC169 Transistors	£1.00
26	BC168 Transistors	£1.00
26	BC167 Transistors	£1.00
26	BC166 Transistors	£1.00
26	BC165 Transistors	£1.00
26	BC164 Transistors	£1.00
26	BC163 Transistors	£1.00
26	BC162 Transistors	£1.00
26	BC161 Transistors	£1.00
26	BC160 Transistors	£1.00
26	BC159 Transistors	£1.00
26	BC158 Transistors	£1.00
26	BC157 Transistors	£1.00
26	BC156 Transistors	£1.00
26	BC155 Transistors	£1.00
26	BC154 Transistors	£1.00
26	BC153 Transistors	£1.00
26	BC152 Transistors	£1.00
26	BC151 Transistors	£1.00
26	BC150 Transistors	£1.00
26	BC149 Transistors	£1.00
26	BC148 Transistors	£1.00
26	BC147 Transistors	£1.00
26	BC146 Transistors	£1.00
26	BC145 Transistors	£1.00
26	BC144 Transistors	£1.00
26	BC143 Transistors	£1.00
26	BC142 Transistors	£1.00
26	BC141 Transistors	£1.00
26	BC140 Transistors	£1.00
26	BC139 Transistors	£1.00
26	BC138 Transistors	£1.00
26	BC137 Transistors	£1.00
26	BC136 Transistors	£1.00
26	BC135 Transistors	£1.00
26	BC134 Transistors	£1.00
26	BC133 Transistors	£1.00
26	BC132 Transistors	£1.00
26	BC131 Transistors	£1.00
26	BC130 Transistors	£1.00
26	BC129 Transistors	£1.00
26	BC128 Transistors	£1.00
26	BC127 Transistors	£1.00
26	BC126 Transistors	£1.00
26	BC125 Transistors	£1.00
26	BC124 Transistors	£1.00
26	BC123 Transistors	£1.00
26	BC122 Transistors	£1.00
26	BC121 Transistors	£1.00
26	BC120 Transistors	£1.00
26	BC119 Transistors	£1.00
26	BC118 Transistors	£1.00
26	BC117 Transistors	£1.00
26	BC116 Transistors	£1.00
26	BC115 Transistors	£1.00
26	BC114 Transistors	£1.00
26	BC113 Transistors	£1.00
26	BC112 Transistors	£1.00
26	BC111 Transistors	£1.00
26	BC110 Transistors	£1.00
26	BC109 Transistors	£1.00
26	BC108 Transistors	£1.00
26	BC107 Transistors	£1.00
26	BC106 Transistors	£1.00
26	BC105 Transistors	£1.00
26	BC104 Transistors	£1.00
26	BC103 Transistors	£1.00
26	BC102 Transistors	£1.00
26	BC101 Transistors	£1.00
26	BC100 Transistors	£1.00
26	BC99 Transistors	£1.00
26	BC98 Transistors	£1.00
26	BC97 Transistors	£1.00
26	BC96 Transistors	£1.00
26	BC95 Transistors	£1.00
26	BC94 Transistors	£1.00
26	BC93 Transistors	£1.00
26	BC92 Transistors	£1.00
26	BC91 Transistors	£1.00
26	BC90 Transistors	£1.00
26	BC89 Transistors	£1.00
26	BC88 Transistors	£1.00
26	BC87 Transistors	£1.00
26	BC86 Transistors	£1.00
26	BC85 Transistors	£1.00
26	BC84 Transistors	£1.00
26	BC83 Transistors	£1.00
26	BC82 Transistors	£1.00
26	BC81 Transistors	£1.00
26	BC80 Transistors	£1.00
26	BC79 Transistors	£1.00
26	BC78 Transistors	£1.00
26	BC77 Transistors	£1.00
26	BC76 Transistors	£1.00
26	BC75 Transistors	£1.00
26	BC74 Transistors	£1.00
26	BC73 Transistors	£1.00
26	BC72 Transistors	£1.00
26	BC71 Transistors	£1.00
26	BC70 Transistors	£1.00
26	BC69 Transistors	£1.00
26	BC68 Transistors	£1.00
26	BC67 Transistors	£1.00
26	BC66 Transistors	£1.00
26	BC65 Transistors	£1.00
26	BC64 Transistors	£1.00
26	BC63 Transistors	£1.00
26	BC62 Transistors	£1.00
26	BC61 Transistors	£1.00
26	BC60 Transistors	£1.00
26	BC59 Transistors	£1.00
26	BC58 Transistors	£1.00
26	BC57 Transistors	£1.00
26	BC56 Transistors	£1.00
26	BC55 Transistors	£1.00
26	BC54 Transistors	£1.00
26	BC53 Transistors	£1.00
26	BC52 Transistors	£1.00
26	BC51 Transistors	£1.00
26	BC50 Transistors	£1.00
26	BC49 Transistors	£1.00
26	BC48 Transistors	£1.00
26	BC47 Transistors	£1.00
26	BC46 Transistors	£1.00
26	BC45 Transistors	£1.00
26	BC44 Transistors	£1.00
26	BC43 Transistors	£1.00
26	BC42 Transistors	£1.00
26	BC41 Transistors	£1.00
26	BC40 Transistors	£1.00
26	BC39 Transistors	£1.00
26	BC38 Transistors	£1.00
26	BC37 Transistors	£1.00
26	BC36 Transistors	£1.00
26	BC35 Transistors	£1.00
26	BC34 Transistors	£1.00
26	BC33 Transistors	£1.00
26	BC32 Transistors	£1.00
26	BC31 Transistors	£1.00
26	BC30 Transistors	£1.00
26	BC29 Transistors	£1.00
26	BC28 Transistors	£1.00
26	BC27 Transistors	£1.00
26	BC26 Transistors	£1.00
26	BC25 Transistors	£1.00
26	BC24 Transistors	£1.00
26	BC23 Transistors	£1.00
26	BC22 Transistors	£1.00
26	BC21 Transistors	£1.00
26	BC20 Transistors	£1.00
26	BC19 Transistors	£1.00
26	BC18 Transistors	£1.00
26	BC17 Transistors	£1.00
26	BC16 Transistors	£1.00
26	BC15 Transistors	£1.00
26	BC14 Transistors	£1.00
26	BC13 Transistors	£1.00
26	BC12 Transistors	£1.00
26	BC11 Transistors	£1.00
26	BC10 Transistors	£1.00
26	BC9 Transistors	£1.00
26	BC8 Transistors	£1.00
26	BC7 Transistors	£1.00
26	BC6 Transistors	£1.00
26	BC5 Transistors	£1.00
26	BC4 Transistors	£1.00
26	BC3 Transistors	£1.00
26	BC2 Transistors	£1.00
26	BC1 Transistors	£1.00
26	BC0 Transistors	£1.00
26	BC-1 Transistors	£1.00
26	BC-2 Transistors	£1.00
26	BC-3 Transistors	£1.00
26	BC-4 Transistors	£1.00
26	BC-5 Transistors	£1.00
26	BC-6 Transistors	£1.00
26	BC-7 Transistors	£1.00
26	BC-8 Transistors	£1.00
26	BC-9 Transistors	£1.00
26	BC-10 Transistors	£1.00
26	BC-11 Transistors	£1.00
26	BC-12 Transistors	£1.00
26	BC-13 Transistors	£1.00
26	BC-14 Transistors	£1.00
26	BC-15 Transistors	£1.00
26	BC-16 Transistors	£1.00
26	BC-17 Transistors	£1.00
26	BC-18 Transistors	£1.00
26	BC-19 Transistors	£1.00
26	BC-20 Transistors	£1.00
26	BC-21 Transistors	£1.00
26	BC-22 Transistors	£1.00
26	BC-23 Transistors	£1.00
26	BC-24 Transistors	£1.00
26	BC-25 Transistors	£1.00
26	BC-26 Transistors	£1.00
26	BC-27 Transistors	£1.00
26	BC-28 Transistors	£1.00
26	BC-29 Transistors	£1.00
26	BC-30 Transistors	£1.00
26	BC-31 Transistors	£1.00
26	BC-32 Transistors	£1.00
26	BC-33 Transistors	£1.00
26	BC-34 Transistors	£1.00
26	BC-35 Transistors	£1.00
26	BC-36 Transistors	£1.00
26	BC-37 Transistors	£1.00
26	BC-38 Transistors	£1.00
26	BC-39 Transistors	£1.00
26	BC-40 Transistors	£1.00
26	BC-41 Transistors	£1.00
26	BC-42 Transistors	£1.00
26	BC-43 Transistors	£1.00
26	BC-44 Transistors	£1.00
26	BC-45 Transistors	£1.00
26	BC-46 Transistors	£1.00
26	BC-47 Transistors	£1.00
26	BC-48 Transistors	£1.00
26	BC-49 Transistors	£1.00
26	BC-50 Transistors	£1.00
26	BC-51 Transistors	£1.00
26	BC-52 Transistors	£1.00
26	BC-53 Transistors	£1.00
26	BC-54 Transistors	£1.00