

Copyright © 2008, Wimborne Publishing Ltd
(Sequoia House, 398a Ringwood Road, Ferndown, Dorset BH22 9AU, UK)
and TechBites Interactive Inc.,
(PO Box 857, Madison, Alabama 35758, USA)

All rights reserved.

The materials and works contained within EPE Online — which are made available by Wimborne Publishing Ltd and TechBites Interactive Inc — are copyrighted.

TechBites Interactive Inc and Wimborne Publishing Ltd have used their best efforts in preparing these materials and works. However, TechBites Interactive Inc and Wimborne Publishing Ltd make no warranties of any kind, expressed or implied, with regard to the documentation or data contained herein, and specifically disclaim, without limitation, any implied warranties of merchantability and fitness for a particular purpose.

Because of possible variances in the quality and condition of materials and workmanship used by readers, EPE Online, its publishers and agents disclaim any responsibility for the safe and proper functioning of reader-constructed projects based on or from information published in these materials and works.

In no event shall TechBites Interactive Inc or Wimborne Publishing Ltd be responsible or liable for any loss of profit or any other commercial damages, including but not limited to special, incidental, consequential, or any other damages in connection with or arising out of furnishing, performance, or use of these materials and works.

READERS' TECHNICAL ENQUIRIES

We are unable to offer any advice on the use, purchase, repair or modification of commercial equipment or the incorporation or modification of designs published in the magazine. We regret that we cannot provide data or answer queries on articles or projects that are more than five years' old. We are not able to answer technical queries on the phone.

PROJECTS AND CIRCUITS

All reasonable precautions are taken to ensure that the advice and data given to readers is reliable. We cannot, however, guarantee it and we cannot accept legal responsibility for it. A number of projects and circuits published in EPE employ voltages that can be lethal. You should not build, test, modify or renovate any item of mains-powered equipment unless you fully understand the safety aspects involved and you use an RCD adaptor.

COMPONENT SUPPLIES

We do not supply electronic components or kits for building the projects featured; these can be supplied by advertisers in our publication Practical Everyday Electronics. Our web site is located at www.epemag.com

We advise readers to check that all parts are still available before commencing any project.



To order your copy for only \$18.95 for 12 issues go to www.epemag.com

EPE HYBRID COMPUTER



PETROS KRONIS

Part 1

Real-time computation of complex system behaviour is greatly simplified by combining analogue and digital processing techniques.

HYBRID computers employ both major categories of electronic systems, the analogue and the digital. As is true with every type of system, each has its advantages and disadvantages. The hybrid system is an attempt to combine the best of both worlds.

Many people imagine analogue computers to be antique units stored away in University laboratories. But not many people realise that in some cases the analogue computer can solve a problem with admirable elegance, ease and simplicity, while the solution of the same problem on the digital computer may be virtually impossible.

A few analogue amplifiers connected together in a few minutes can give the solution to a complex problem with the units producing results in real time. A similar problem may take months to be programmed on the digital computer, provided the programmer has the skill to solve the equations.

For the digital computer to execute the program, millions of iterations have to be performed, and not in real time. Granted digital computers are now very fast, but

those tiny periods of time necessary to perform the iterations add up to considerable time periods. If anyone is still skeptical, visit the following site on the internet:

www.indiana.edu/~rcapub/v21n2/p24.html

There, you will meet Dr Jonathan Wayne Mills, associate professor of computer science at Indiana University, Bloomington, and director of the Adaptive Systems Laboratory, whose patented new analogue computer uses radically simplified electronic components and "continuous value logic" circuits, that make his computer able to work incredibly fast and process more sensory inputs than a digital computer can handle.

ANALOGUE COMPUTER

An analogue computer uses voltage as the *analogue* to represent a physical quantity, in the same way that the height of the mercury column of an old fashioned mercury thermometer represents temperature.

The analogue computer is designed to solve mathematical equations, in particular differential equations, which are especially

SPECIFICATION

- Ten analogue amplifiers
- Each amplifier can be operated as an Adder or Integrator
- Eight coefficient multipliers
- Over-voltage indicators on all amplifiers
- Three modes of operation, Compute, Hold and Reset
- Automatic or Manual mode control
- Offset null on all amplifiers
- ATOM microcontroller:
 - 8k Flash program memory
 - 384 bytes of RAM
 - 15 I/O pins
 - RS232 serial link
 - Analogue-to-digital converter
 - PWM and Timer functions
 - BASIC compiler programming
 - Integrated Development Environment (IDE)

difficult to solve manually. Differential equations describe the behaviour of physical systems, such as the suspension system of a motor car or the flight of a rocket.

The variables involved in such systems, such as the stiffness of the springs in the first example, or the thrust of the engine in the second, can be varied by simply turning the dial of a potentiometer. In this way the behaviour of the systems can be simulated, and many experiments carried out without going to the expense of constructing and testing real models.

Other advantages of the analogue computer are the speed with which it carries out the processing, and the relative simplicity with which one can formulate the problem on the computer. The disadvantage is that the range of voltage variation is limited and the measurement of that voltage is prone to errors. However, engineering is not an exact science and the analogue computer is a useful tool in the design of many engineering systems.

DIGITAL COMPUTER

In contrast to its analogue counterpart, the digital computer works by manipulating discrete voltage pulses, instead of continuously varying voltages. It has the advantage of high accuracy and repeatability of results. On the other hand, it is difficult and time consuming to program a digital computer to solve differential equations and, moreover, the programmer must

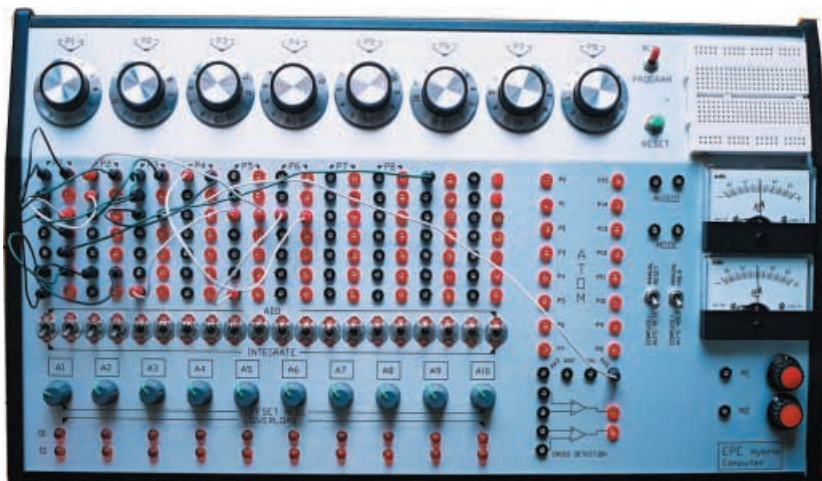

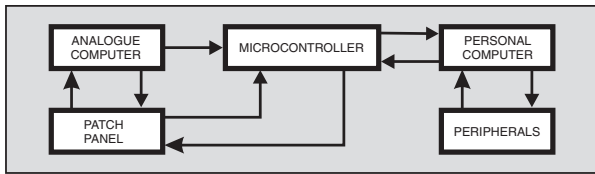

Fig. 1. Block diagram of EPE Hybrid Computer.

have the mathematical ability to solve the equations in order to write the program.

The EPE Hybrid Computer employs an ATOM microcontroller system, which operates in conjunction with the analogue system and can be programmed to control it. Moreover, it can be programmed to analyse and transmit information to a PC for the display of results or for further processing if required. Fig.1 shows a diagram of the arrangement.

The analogue system is programmed by connecting its modules using wires through a patch panel. The microcontroller (MCU) has access to the control circuits of the analogue computer through the patch panel. Programming of the MCU is carried out in BASIC by means of a BASIC compiler resident in the PC (see later). Communication is through a serial link.

The MCU sends and receives data through its input and output ports and has the capability to convert analogue signals to digital by means of the built in analogue-to-digital converter (ADC).

MAIN UNITS

The heart of the analogue computer is formed around several high gain d.c. amplifiers, or operational amplifiers (op.amps). By connecting the op.amps to various input and feedback

components, certain mathematical operations can be performed. These are, addition (and subtraction), integration, and multiplication by a constant. Differentiation can also be performed, but is generally avoided due to problems associated with noise generated by components.

Addition circuit

The diagram in Fig.2 shows the Addition circuit in which resistors are connected to the input and feedback loop of the op.amp to perform input voltage addition. The output voltage is given by:

$$V_o = -\left(\frac{R_f}{R_1}V_1 + \frac{R_f}{R_2}V_2 + \frac{R_f}{R_3}V_3 + \frac{R_f}{R_4}V_4\right)$$

Integrator circuit

With the Integrator circuit (Fig.3), with capacitor C_f in the output voltage is given by:

$$V_o = -\left(\frac{1}{R_1C_f} \int V_1 dt + \frac{1}{R_2C_f} \int V_2 dt + \frac{1}{R_3C_f} \int V_3 dt + \frac{1}{R_4C_f} \int V_4 dt\right)$$

Coefficient Multiplier

The Coefficient Multiplier (Fig.4) is used to multiply a voltage by a constant number between zero and one. This mathematical operation is usually performed without the use of an op.amp. A potentiometer is connected as shown in Fig.4. At one extreme of the slider's travel $V_o = V_{in}$, i.e. V_{in} is multiplied by one, whereas at the other extreme $V_o = 0$, i.e. V_{in} is multiplied by zero.

Any intermediate value can be set up by moving the slider. The dial of the potentiometer can be calibrated to facilitate this. However, because of the effects of load resistance, it is usual practice to measure the potentiometer output after the circuit has been connected and to ignore the scale on the dial.

By choosing suitable values for the input and feedback components, Adders and Integrators can also be arranged to apply a multiplication factor to the input voltages. Fig.5 shows the symbols and the function of each unit used in the EPE Hybrid Computer.

The circuits just described form the fundamental building blocks of an analogue computer. Other specialised circuits, such as four-quadrant multipliers, and various non-linear circuits, can be used to simulate effects such as backlash, friction, dead space, absolute values, etc., although they are not the subject of this design.

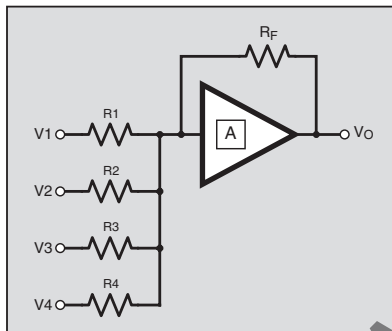

Fig.2. The Addition circuit.

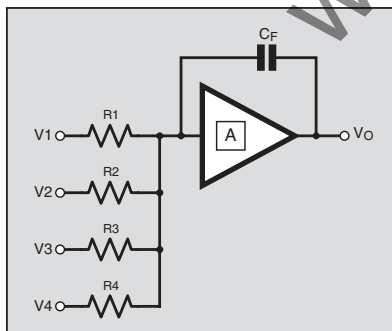

Fig.3. The Integrator circuit.

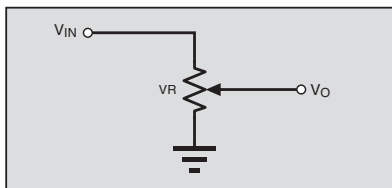

Fig.4. The Coefficient Multiplier

| | | |
|------------------------|---|--|
| COEFFICIENT MULTIPLIER | MULTIPLICATION OF A VARIABLE BY A POSITIVE CONSTANT COEFFICIENT $0 < k < 1$ | INPUT X OUTPUT kX |
| INVERTER | SIGN REVERSING, I.E. MULTIPLICATION OF A VARIABLE BY -1 | INPUT X OUTPUT -X |
| ADDER | ADDITION OF VARIABLES INCLUDING MULTIPLICATION BY 1 OR 10 | INPUTS X, Y, Z, W OUTPUT $-(X+Y+10Z+10W)$ |
| SUMMER INTEGRATOR | SUMMATION OF THE INTEGRALS OF VARIABLES WITH RESPECT TO TIME | INPUTS X, Y, Z, W OUTPUT $-\int(X+Y+10Z+10W)$ |

Fig.5. Analogue computer units, their function and symbols.

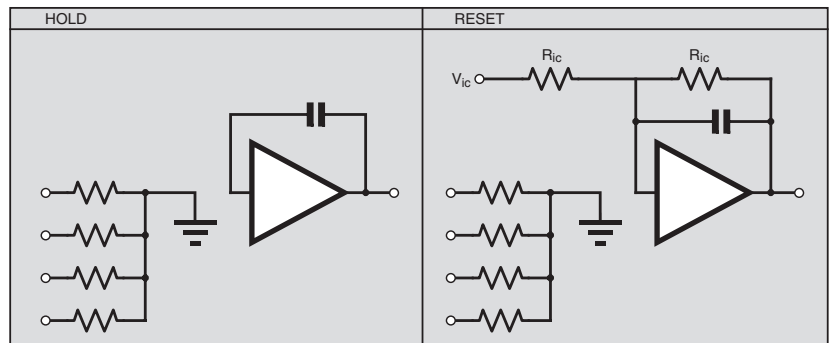

Fig.6. Circuit changes for integrators for the Hold and Reset modes.

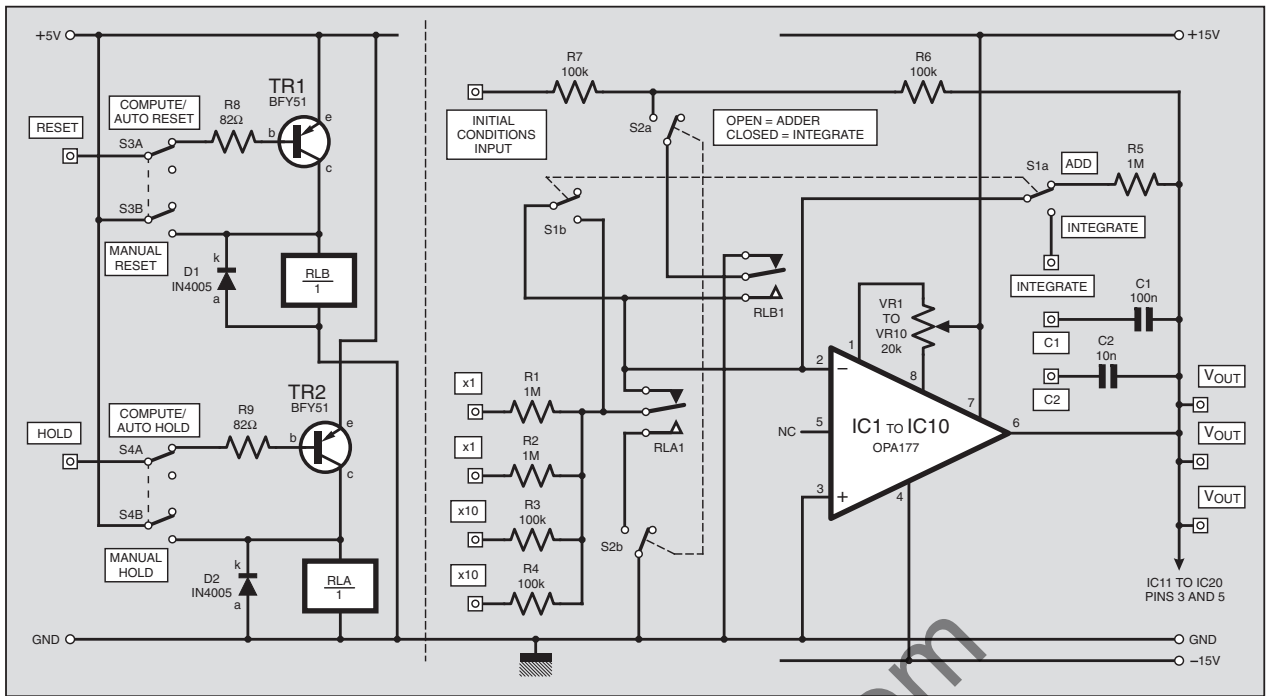

Fig.7. Circuit diagram for the Analogue Amplifier. Ten copies of this circuit are required to be built.

ANALOGUE COMPUTER CONTROL

Circuits which control the mode of operation of the analogue computer are necessary. The EPE Hybrid Computer can be operated in three modes, Compute, Hold, and Reset. In addition, an overload warning system is included which monitors the outputs of all amplifiers and gives a warning when they are about to saturate.

In the Compute mode the computer carries out the solution of the problem. Prior to this, the computer is placed in the Reset, or initial conditions mode in which the variables are allowed to take their initial values before computation begins. This mode of operation is also called "problem check". It is sometimes desirable to stop the computation to take some measurements. This is achieved by placing the computer into the Hold mode.

In the case of Adders, no change in the circuits is necessary for mode control. However, the Integrators have to be modified as shown in Fig.6.

ANALOGUE AMPLIFIER

The circuit diagram for the Analogue Amplifier is shown in Fig.7. Ten copies of this circuit are required.

Many op.amp i.c. types can be used to make an analogue computer circuit, from the ubiquitous 741, to advanced auto-zeroed chopper stabilised op.amps such as the Microchip TC901. The device selected for this amplifier is the OPA177 high

precision op.amp, which gives very good performance at a reasonable cost.

Resistors R1 to R4 are the input resistors and R5, plus capacitors C1 and C2, are the feedback components. The values chosen give a multiplication factor of $\times 1$ and $\times 10$, to signals connected to the respectively notated inputs.

Moreover, when the amplifier operates as an Integrator, the programmer can choose C1 or C2 to be the feedback capacitor, by connecting leads to the appropriate patch panel sockets. If C2 is selected then input signals are multiplied by an additional factor of 10. In computer jargon this is known as an amplifier with a "nose gain" of 10. This means that input signals connected to resistors R1 or R2 will be multiplied by a factor of 10, whereas signals connected to R3 or R4 will be multiplied by a factor of 100.

Switches S1a, S1b, S2a and S2b, and relays RLA and RLB enable the amplifiers to be operated as Adders or Integrators, and additionally allow the selection of the three modes of operation. Relays are used instead of solid state switching to provide the total signal isolation as required. Table 1 shows the positions of these switches and relays to achieve these conditions.

Switches S4 and S3 are used to operate relays RLA and RLB

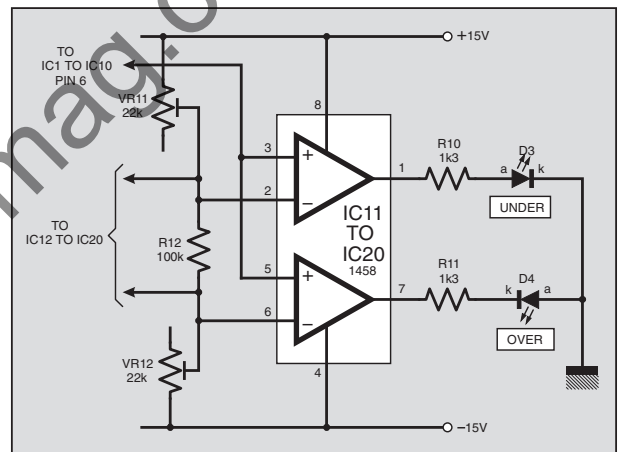

Fig.8. Overload warning circuit, ten are used.

respectively. In the position shown in the diagram the amplifiers are operating in the Compute mode but if the patch panel sockets are connected to the ATOM I/O (input/output) pins, then the ATOM has control and can place the analogue amplifiers in the Hold or Reset modes under program control.

Transistors TR1 and TR2 are necessary to amplify the signal, as the 10 relays can draw a large amount of current. Diodes D1 and D2 protect the transistors from the back e.m.f. created by the collapsing current in the coils of the relays as these are switched OFF.

OTHER SUB-CIRCUITS

Overload warning system

The Overload Warning circuit is shown in Fig.8 and is built around the 1458 dual op.amp. Reference voltages of +13V and -13V are produced across resistor R12 as set by potentiometers VR11 and VR12, and applied to the inverting inputs of IC11 to IC20. The output of each amplifier (IC1 to IC10) is applied to the non-inverting inputs

Table 1. The position of switches and relays for mode control.

| Switch | Adder | | | Integrator | | |
|--------|---------|--------|-------|------------|--------|-------|
| | Compute | Hold | Reset | Compute | Hold | Reset |
| RLA | 1 | 2 | 2 | 1 | 2 | 2 |
| RLB | 1 | 1 | 2 | 1 | 1 | 2 |
| S1a | 1 | 1 | 1 | 2 | 2 | 2 |
| S1b | | Closed | | | Open | |
| S2a | | Open | | | Closed | |
| S2b | | Open | | | Closed | |

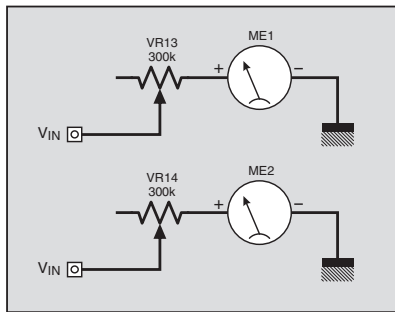

Fig. 9. Analogue voltage monitoring circuits.

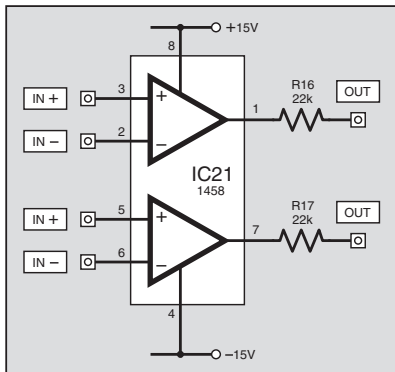

Fig. 10. Reference Voltage Cross-Detection circuit.

of the overload op.amps (IC11 to IC20). Light emitting diodes (l.e.d.s) D3 and D4 are lit when the amplifier output voltage exceeds its reference voltage.

Analogue display

Panel meters ME1 and ME2, as shown in Fig. 9, can be used to display the output of the analogue amplifiers. Potentiometers VR13 and VR14 provide sensitivity control. These units are useful when the programmer wishes to monitor an output without going to the trouble of transferring the results to the PC.

Reference voltage cross detection

The Reference Voltage Cross-Detection circuit in Fig. 10 also uses the 1458 dual op.amp. It can be used to produce a control signal when a voltage crosses a predefined value.

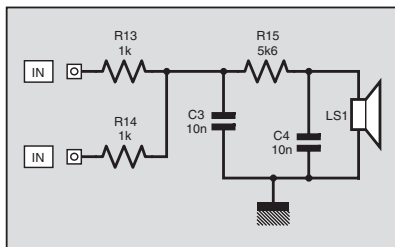

Fig. 11. Audio circuit.

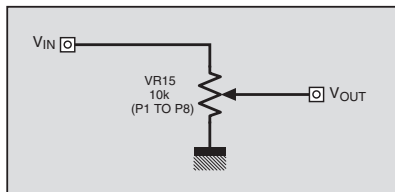

Fig. 12. Coefficient Multiplier. Eight are used.

To give an example, assume that the computer has been programmed to simulate the landing of an aircraft. As the aircraft descends, the computer is unaware that the height cannot take a negative value and will continue the flight below ground!

To avoid this, a reference voltage of zero can be applied to the detection circuit to produce a signal when the value of zero is crossed. This signal can be passed to the microcontroller to take the appropriate action when this happens, e.g. to stop the computation.

Resistors R16 and R17 limit the current which will flow into the I/O pins of the ATOM.

Audio circuit

The Audio circuit, shown in Fig. 11, has been included to allow the ATOM to produce audible warning sounds if required. The BASIC commands available allow the programmer to write code to play more complex sounds, and even music.

Coefficient multiplier

The Coefficient Multiplier is simply a single potentiometer, VR15, as shown in Fig. 12. Eight copies of this circuit are required.

MICROCONTROLLER CIRCUIT

The circuit diagram for the Basic Micro ATOM microcontroller is shown in Fig. 13.

The ATOM has the advantage of being programmable in BASIC, a simple but powerful language. Programs can be written and loaded into the ATOM at will, and the last program loaded remains resident even if the power is removed.

As can be observed, the circuit is simple as all the complexity is inside the chip. The only connections necessary are the I/O pins to the patch panel sockets and the serial link connections to socket SK1. A provision has been made for connecting a liquid crystal display (l.c.d.) to socket SK1. A provision has been made for connecting a liquid crystal display (l.c.d.) for those who wish to use one, writing their own program to do so.

POWER SUPPLY

This design requires an external d.c. power supply, with outputs of +15V, -15V, +5V and 0V. The supplies of +15V and -15V must be regulated. The +5V supply does not need to be regulated as the ATOM microcontroller has an on-board voltage regulator. This is provided to the ATOM's V_{in} pin 24 (with its V_{dd} pin 21 being left unconnected). Power supplies can be constructed using the appropriate voltage regulator i.c.s (7815, 7915 and 7805).

For the prototype, an old PC computer power supply was used. These power supplies give +12V, -12V, +5V and various other output voltages. The voltage range is slightly reduced, but it is a convenient

solution for those who do not want to build their own power supply.

PRINTED CIRCUIT BOARDS

To reduce the amount of wiring inside the box, the double-sided printed circuit boards (p.c.b.s), of which there are two, were designed to accommodate all components, including the patch panel sockets and the mode switches. The exceptions are the Coefficient Multiplier potentiometers and the two panel meters with their associated input sockets and sensitivity potentiometers.

The fact that the mode switches are soldered on the p.c.b. and are also connected to the front panel, means that the p.c.b. lies about 15mm behind the front panel. The space between the front panel and the p.c.b. is just enough to accommodate the components with the switches effectively acting as the main support for the board.

The 1mm patch panel sockets used on the prototype were too short but this was easily solved by soldering small bare wire extensions to the sockets before soldering these on the p.c.b. The component layout for the main p.c.b. is shown in Fig. 14, and that for the ATOM microcontroller board in Fig. 17 later.

Track layout details for the boards are not shown separately as their size and double-sided requirement make them unsuited for normal hobbyist manufacture. Full-size photocopies of the printed circuit board track master patterns can be supplied to readers via the Editorial office on request. Enclose a self-addressed envelope, stamped to suit four A4 pages.

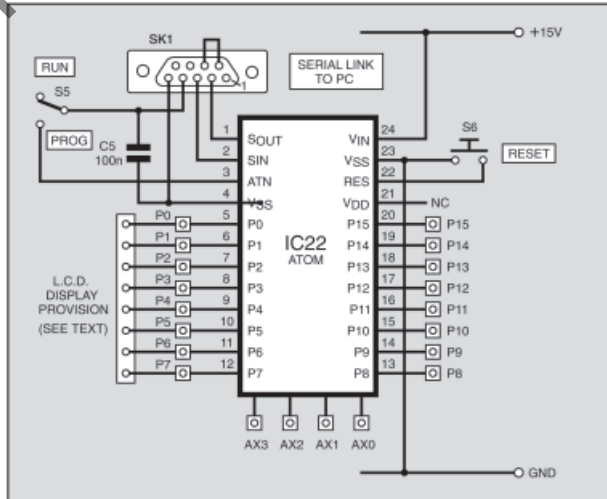

Fig. 13. Connections to the Basic Micro ATOM microcontroller.

The boards are available ready-made from the *EPE PCB Service*, codes 375 (Main) and 376 (ATOM).

P.C.B. ASSEMBLY

Solder the components of the main p.c.b. in the following sequence:

Use double-sided solder pins, suited to 0.8mm holes, to connect the two sides of the p.c.b. Resistor off-cut wires will be satisfactory as an alternative.

Because alignment is critical, the mode switches and the l.e.d.s have to be soldered while being assembled with the front panel (shown in Fig. 15.). Attach the switches to the front panel, position the l.e.d.s in the

HYBRID COMPUTER MAIN P.C.B.

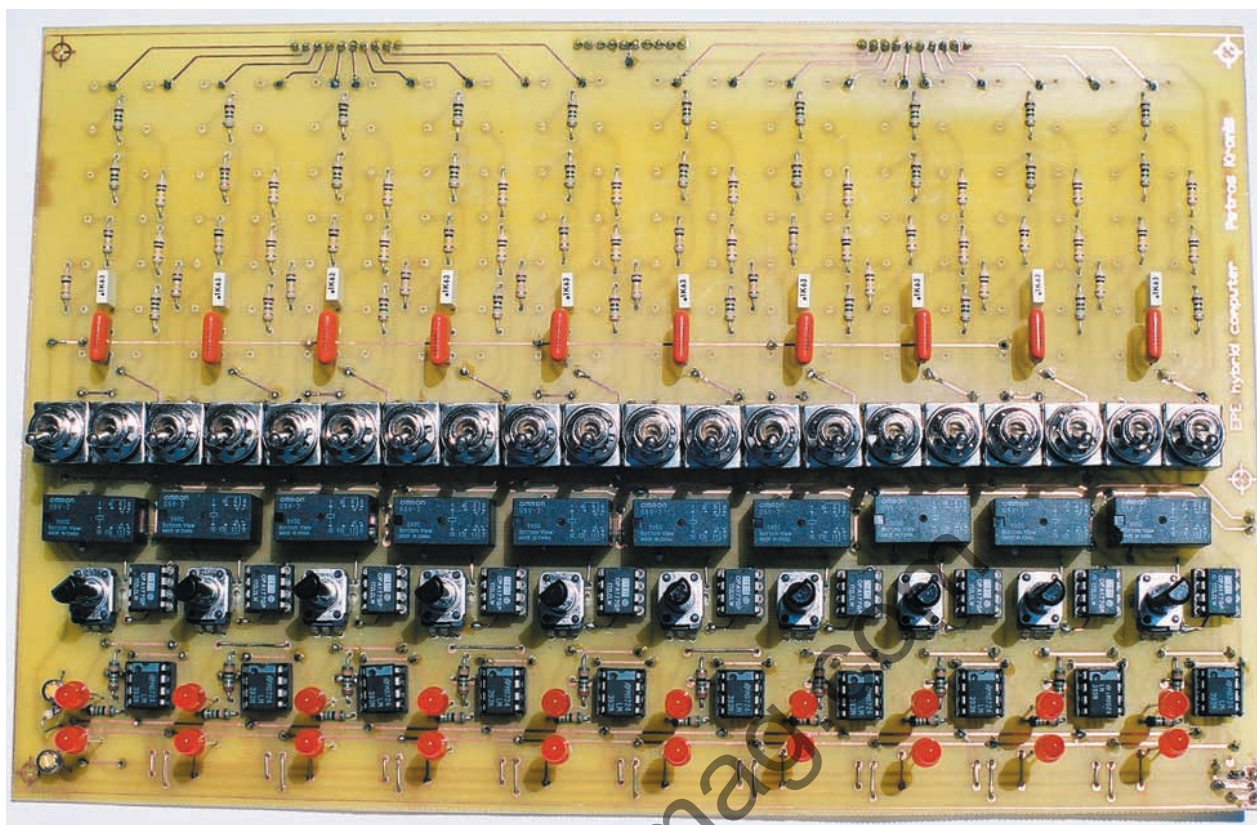

Care must be taken when assembling that the switches, potentiometers, l.e.d.s and sockets align with the front panel holes. The sockets need to be mounted last, their extension leads going into the holes just visible in the upper part of the above photo. A socket functions diagram will be given in Part 2.

COMPONENTS

Approx. Cost
Guidance Only

£220
excl. case

Resistors

| | |
|------------------------|---------------------|
| R1, R2, R5 | 1M 2% (30 off) |
| R3, R4, R6, R7, R12 | 100k 2% (41 off) |
| R8, R9 | 82Ω (2 off) |
| R10, R11 | 1k3 (20 off) |
| R13, R14 | 1k (2 off) |
| R15 | 5k6 |
| R16, R17 | 22k (2 off) |

All 0.25W carbon film, 5% except where marked.

Potentiometers

| | |
|----------------|---|
| VR1 to VR10 | 20k (or 22k) lin., p.c.b. mounting, vertical, rotary (10 off) |
| VR11, VR12 | 22k, min. preset, round (2 off) |
| VR13, VR14 | 300k (or 330k) lin., panel mounting, rotary (2 off) |
| VR15 | 10k lin., panel mounting, rotary (8 off) |

Capacitors

| | |
|------------|----------------------------------|
| C1, C5 | 100n ceramic, 5mm pitch (11 off) |
| C2, C3, C4 | 10n ceramic, 5mm pitch (12 off) |

Semiconductors

| | |
|--------|--------------------------------|
| D1, D2 | 1N4005 rectifier diode (2 off) |
|--------|--------------------------------|

See
**SHOP
TALK**
page

| | |
|--------------|--|
| D3, D4 | red l.e.d., 5mm (20 off) |
| TR1, TR2 | BFY51 <i>n</i> p <i>n</i> transistor (2 off) |
| IC1 to IC10 | OPA177 dual precision op.amp (10 off) |
| IC11 to IC21 | MC1458 dual op.amp (11 off) |
| IC22 | Basic Micro ATOM microcontroller (see text) |

Miscellaneous

| | |
|----------|---|
| RLA, RLB | d.p.c.o. relay, p.c.b. mounting, 5V coil (10 off) |
| S1 to S4 | min. d.p.d.t. toggle switch, (22 off) |
| S5 | min. s.p.d.t. toggle switch |
| S6 | min. s.p.s.t. push-to-make switch |
| ME1, ME2 | ±100μA panel meter (2 off) |
| LS1 | piezo buzzer |
| SK1 | 9-way D-type female connector |

Printed circuits boards, available from the *EPE PCB Service*, codes 375 (Main), 376 (ATOM); 1mm patch panel sockets, black (84 off); red (88 off); power supply sockets (see text) (4 off); 0.8mm (dia.) solder pins (see text); plastic case with sloped panel, (see Fig.16); knobs with skirts marked 1 to 10 (8 off); small knobs (10 off); medium knobs (2 off); 1mm pin-header strips, cut to length required; connecting wire; solder; etc.



Edge-on view showing front panel and p.c.b. relationship.

correct orientation into the p.c.b. (note that the polarity of l.e.d. D4 is opposite to that of l.e.d. D3). Carefully press the p.c.b. onto the switches and then solder as required. Then align the l.e.d.s in position, and solder them.

Remove the p.c.b. from the front panel and solder the remaining components, i.e. capacitors, relays, potentiometers and 1mm pin-header strip connectors.

Thoroughly check for defects in component positioning and soldering. If everything is satisfactory, attach the p.c.b. back onto the front panel.

Pass the patch panel sockets into the front panel holes carefully (and patiently!) pushing their rigid wire extensions through the p.c.b. holes and solder in position.

Note that it is preferable to use patch panel sockets which have the securing nut on top, i.e. on the same side as the switches. Otherwise, if the nuts are on the opposite

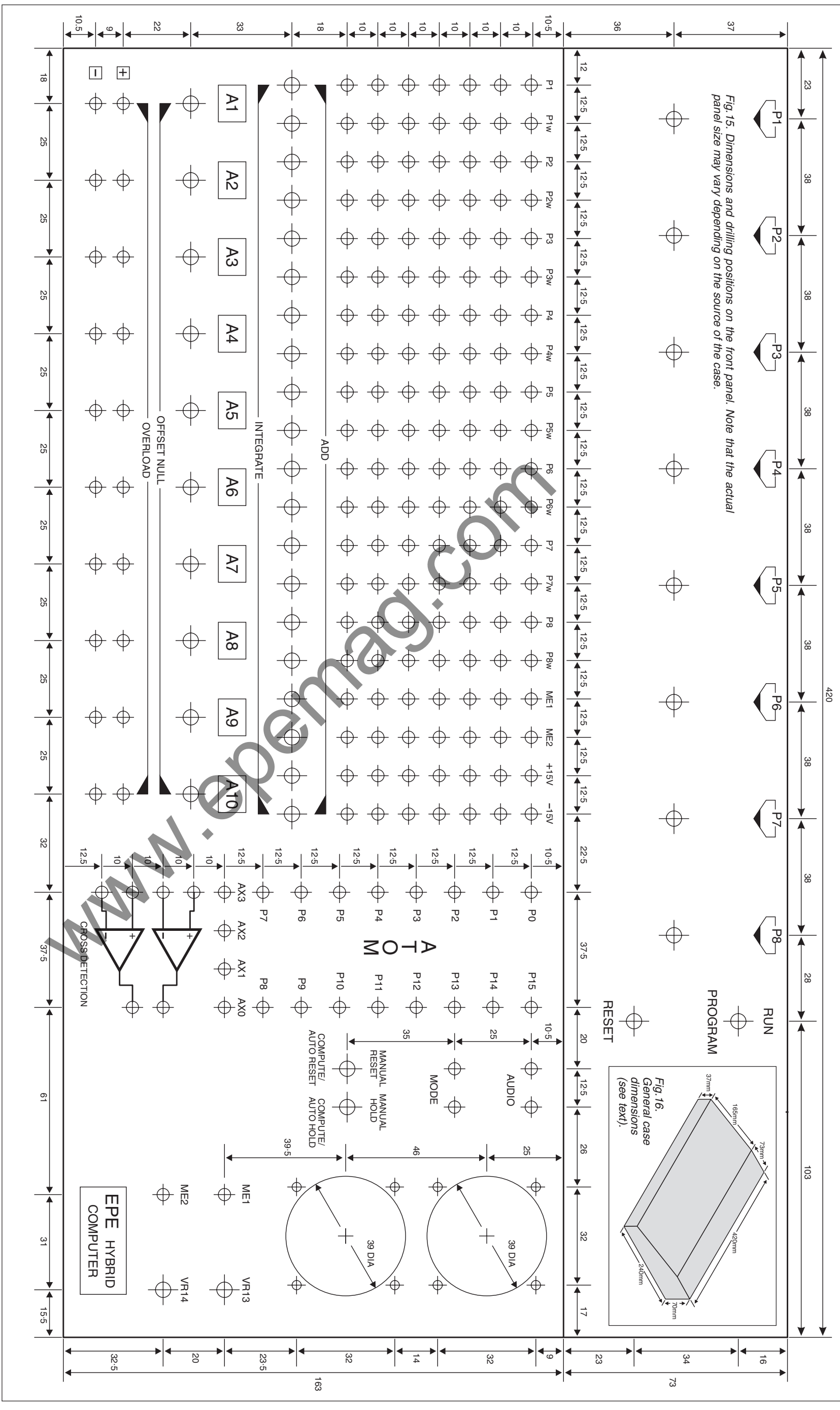

Fig. 15. Dimensions and drilling positions on the front panel. Note that the actual panel size may vary depending on the source of the case.

side (behind the front panel), then once soldered the p.c.b. will not be able to be removed from the front panel.

FRONT AND REAR PANELS

The computer was housed in a box with a sloping front panel. Fig.15 shows the design of the front panel with all the locations necessary to drill the holes for the components.



The general dimensions of the box are shown in Fig.16, but may vary depending on the source of the case. The layout of the rear panel is shown in the photograph. The four power supply connectors were 4mm sockets in the prototype, and should be labelled appropriately. The 9-way D-type socket connects via a suitable lead to the PC's COM2 serial port.

- Power supply sockets to the 1mm p.c.b. pin-header connectors.
- SK1 serial socket to p.c.b. connector.
- P.C.B. connectors to coefficient multiplier potentiometers and the return to earth.
- Panel meter wiring. Note that panel meters may have connectors for illumination of the dials. Use either the +15V

or the -15V to supply the bulbs. This is useful as the panel meter lights function also as power on indicators. Photographs of some aspects of the case assembly are in Part 2.

ATOM BOARD

The ATOM p.c.b. (Fig.17) is soldered to the front panel sockets in a similar

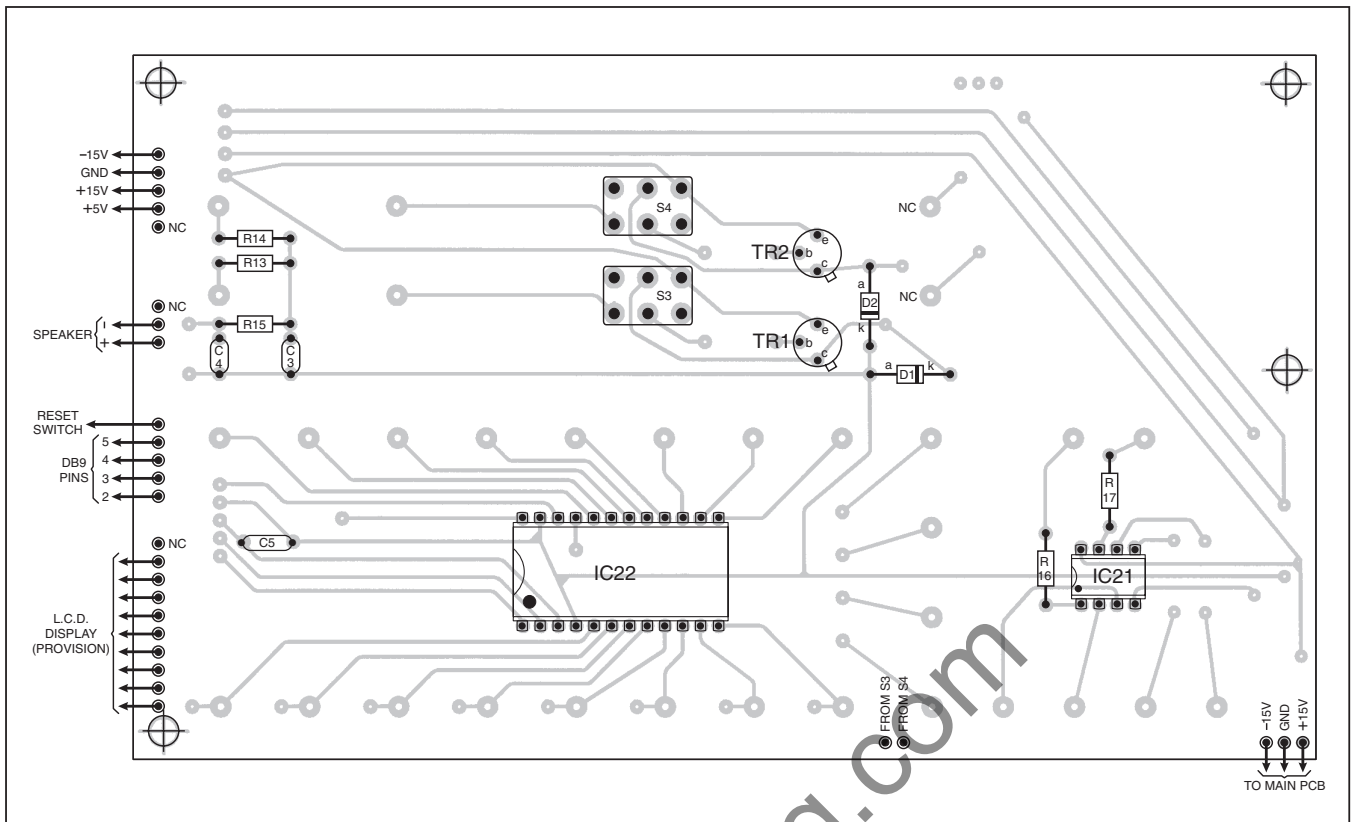

Fig. 17. Component layout details for the ATOM microcontroller p.c.b.

way to the main board. The ATOM i.c. used in the prototype had four small pads at the back of it (these are the ADC pins), which must be connected with four short wires to the p.c.b. (see photo).

This is a very delicate operation and **must be done with extreme care** as the pads are tiny and very close together. Use a very small soldering iron tip and melt a small amount of solder onto the wire ends. Then looking through a magnifying glass hold the wire end on the pad and touch the tip of the soldering iron on the wire and pad momentarily to make the connection.

Whilst "carrying the solder" on the iron is not normally recommended, if you do so with sufficient haste (but with care) the solder quality should not deteriorate significantly.

Once complete, use a multimeter to check that a solder bridge has not been made between the pads.

NEXT MONTH

In the concluding part next month, testing the various aspects of the design is described. Examples are then given illustrating how the computer can be used to simulate real-world engineering problems, such as encountered when loading a spring, or demonstrating the take-off and landing of a Harrier jump jet!

RESOURCES

VB6 software for this project is available for free download from the *EPE* ftp site, or on CD-ROM (for which a charge applies) from the *EPE* Editorial office, see the *EPE PCB Service* page for details. Software for the ATOM can be supplied on CD-ROM when you buy this microcontroller (see this month's *Shoptalk* page for details) or can be downloaded from www.basicmicro.com.

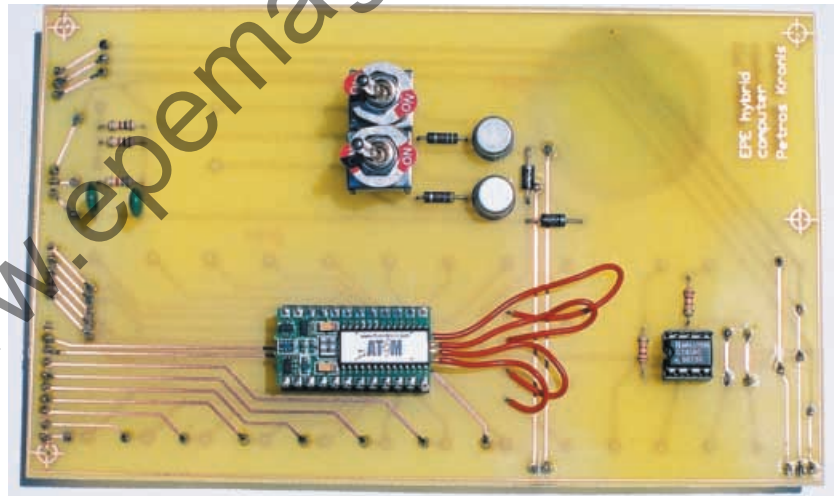

Prototype ATOM p.c.b.

